

ENVIRONMENTAL PROTECTION AGENCY

40 CFR Part 60

[EPA-OAR-2002-0071; FRL-]

RIN 2060-AK61

Update of Continuous Instrumental Test Methods

AGENCY: Environmental Protection Agency (EPA).

ACTION: Final rule.

SUMMARY: On October 10, 2003, the EPA proposed amendments to update five instrumental test methods that are used to measure air pollutant emissions from stationary sources. These amendments are finalized in this document and reflect changes to the proposal to accommodate the public comments. This action is made to improve the methods by simplifying, harmonizing, and updating their procedures. A large number of industries are already subject to provision that require the use of these methods. Some of the affected industries and their North American Industrial Classification System (NAICS) are listed under SUPPLEMENTARY INFORMATION.

DATES: This final rule is effective on [insert date 90 days after publication in the Federal Register].

ADDRESSES: EPA has established a docket for this action under Docket ID No. OAR-2002-0071. All documents in the

docket are listed on the www.regulations.gov web site. Although listed in the index, some information is not publicly available, e.g., CBI or other information whose disclosure is restricted by statute. Certain other material, such as copyrighted material, is not placed on the Internet and will be publicly available only in hard copy form. Publicly available docket materials are available either electronically through www.regulations.gov or in hard copy at the Air and Radiation Docket, Docket ID No. OAR-2003-0071, EPA Docket Center (EPA/DC), EPA West, Room B102, 1301 Constitution Ave., NW, Washington, DC. The Public Reading Room is open from 8:30 a.m. to 4:30 p.m., Monday through Friday, excluding legal holidays. The telephone number for the Public Reading Room is (202) 566-1744, and the telephone number for the Air and Radiation Docket is (202) 566-1742.

FOR FURTHER INFORMATION CONTACT: Foston Curtis,
Measurement Technology Group (E143-02), Air Quality
Assessment Division, EPA, Research Triangle Park, North
Carolina 27711; telephone (919) 541-1063; fax number (919)
541-0516; electronic mail address: *curtis.foston@epa.gov*.

SUPPLEMENTARY INFORMATION:

I. General Information

A. Affected Entities. Categories and entities potentially regulated by the final rule include the following:

Examples of Regulated Entities	SIC Codes	NAICS Codes
Fossil Fuel Steam Generators	3569	332410
Industrial, Commercial, Institutional Steam Generating Units	3569	332410
Electric Generating	3569	332410
Stationary Gas Turbines	3511	333611
Petroleum Refineries	2911	324110
Municipal Waste Combustors	4953	562213
Kraft Pulp Mills	2621	322110
Sulfuric Acid Plants	2819	325188

This table is not intended to be exhaustive, but rather provides a guide for readers regarding entities likely to be affected by this action. This table lists examples of

the types of entities EPA is now aware could potentially be affected by the final rule. Other types of entities not listed could also be affected. If you have any questions regarding the applicability of this action to a particular entity, consult the person listed in the preceding FOR FURTHER INFORMATION CONTACT section.

B. Worldwide Web. In addition to being available in the docket, an electronic copy of today's final rule amendments will also be available on the Worldwide Web (WWW) through the Technology Transfer Network (TTN). Following the Administrator's signature, a copy of the final rule will be placed on the TTN's policy and guidance page for newly proposed or promulgated rules at <http://www.epa.gov/ttn/oarpg>. The TTN provides information and technology exchange in various areas of air pollution control.

C. Judicial Review. Under Section 307(b)(1) of the Clean Air Act (CAA), judicial review of the final rule is available only by filing a petition for review in the U.S. Court of Appeals for the District of Columbia Circuit by [INSERT DATE 60 DAYS AFTER PUBLICATION OF THE FINAL RULE IN THE FEDERAL REGISTER]. Under Section 307(d)(7)(B) of the CAA, only an objection to the final rule that was raised

with reasonable specificity during the period for public comment can be raised during judicial review. Under CAA section 307(b)(2), the requirements established by the final rule may not be challenged later in civil or criminal proceedings brought by EPA to enforce these requirements.

D. Outline. The information presented in this preamble is organized as follows:

I. Background

II. Summary of Major Comments and Revisions Since Proposal

A. Uncertainty Calculation

B. Sampling System Bias

C. Calibration Drift Test

D. Analyzer Calibration Error Test

E. Interference Test

F. Alternative Dynamic Spike Procedure

G. Sampling Traverse Points

H. Sampling Dilution Systems

I. Equipment Heating Specifications

J. Technology-Specific Analyzers

K. Calibration Gases

L. Method 7E Converter Test

III. Summary of Environmental, Energy, and Economic Impacts

- A. Executive Order 12866: Regulatory Planning and Review
- B. Paperwork Reduction Act
- C. Regulatory Flexibility Act
- D. Unfunded Mandates Reform Act
- E. Executive Order 13132: Federalism
- F. Executive Order 13175: Consultation and Coordination with Indian Tribal Governments
- G. Executive Order 13045: Protection of Children from Environmental Health and Safety Risks
- H. Executive Order 13211: Action Concerning Regulations that Significantly Affect Energy Supply, Distribution, or Use
- I. NTTAA: National Technology Transfer and Advancement Act
- J. Congressional Review Act

I. Background

Methods 3A, 6C, 7E, 10, and 20 are instrumental procedures used to measure oxygen, carbon dioxide, sulfur dioxide, nitrogen oxides, and carbon monoxide emissions in stationary sources. They are prescribed for determining compliance with a number of Federal, State, and Local regulations. Amendments to update these methods were

originally proposed on August 27, 1997 (62 FR 45369) as part of an action to update the test methods in 40 CFR Parts 60, 61, and 63. Eight comment letters were received from this proposal with comments pertinent to Methods 3A, 6C, 7E, 10, and 20. Some commenters thought insufficient notification was given in the preamble for the changes being proposed and asked that the instrumental method revisions be repropose as a separate action. This separate proposal was published on October 10, 2003 (68 FR 58838) and contained additional revisions not included in the first proposal. Sixty one comment letters were received from this second proposal. These comments along with the comments received from the first proposal were used to make the appropriate changes to the proposed revisions.

II. Summary of Major Comments and Revisions Since Proposal

A. Uncertainty Calculation. Numerous commenters disliked the proposed requirement to calculate data uncertainty in the method results and thought it inappropriate and confusing. It was noted that existing emission limitations were developed using emission data derived principally from these same test methods with no consideration of uncertainty. Further, the purpose of the

federal test methods is to provide a means of demonstrating compliance with the applicable requirements on the basis of the test method results. Most commenters objected to allowing regulatory agencies (or data end users) the discretion of accepting data close to an emission limit if the uncertainty determination is questionable, especially since no criteria for acceptable uncertainty were identified. The commenters thought that measurement uncertainty and data quality objectives present a number of very serious issues that are too easy for those without a thorough understanding of statistics to misapply. The resulting gray areas would incite many frivolous lawsuits by those who would use the perception of uncertainty to continuously challenge any decision made related to compliance. The commenters noted that the proposed revisions failed to provide a definition for uncertainty and the proposed uncertainty calculation reflected only two factors (sampling system bias and converter efficiency) that contribute to uncertainty, rather than all potential measurement factors. They preferred the tester and facility have a reasonable assurance that they have met the test requirements based on a properly quality assured test, not on an untenable uncertainty calculation.

A number of commenters recommended retaining the bias-corrected data calculation currently in Method 6C in place of the proposed data uncertainty calculation.

We agree with the commenters and have dropped the proposed requirement to calculate measurement uncertainty. The methods will retain a bias-correction for the sample concentration similar to what is current in Method 6C.

B. Sampling System Bias. Several commenters found the proposed sampling system bias calculation that is based on the emission standard problematic because some units have no emission limit, others have more than one limit, and still others have limits in units other than concentration (e.g., lbs/hr, lb/mm BTU, or lb/ton feed). Most believed analyzer performance and accuracy are best evaluated as a function of analyzer span. One commenter wondered why the proposed bias test was based on the emission standard, while the other performance tests were not.

In the proposal, the conversion table for sources that have standards in units other than concentration and the note in Section 1.3.3 advising the test to be designed around the most stringent standard in cases of multiple standards were attempts to alleviate the problems the

commenters noted. We proposed using the emission limit in place of the span in the bias calculation to relieve what was thought to be an increased burden of passing the test when lower spans are chosen. The intent was to have testers use a consistent value in the denominator of the bias equation and emphasize the greatest accuracy in the range of the emission standard. This approach appears to have added more complication than it was intended to relieve.

In the final rule, the proposed change to calculate the bias relative to the emission standard has been dropped. The bias determination as a percentage of the span is retained. However, "span" has been changed to "calibration span" which is equivalent to the concentration of the high calibration gas as in the proposal. In the current methods, the span is any number that doesn't result in the emission standard being less than 30 percent of the span. The high calibration gas chosen for this span must then be 80-100 percent of the span. This allows a concentration interval between the high calibration gas and the span that is not quality assured. This interval has been eliminated.

The traditional "span" was often mistaken for and used interchangeably with "analyzer range." With the "calibration span," only the calibrated portion of the

analyzer range is of concern, and any value that exceeds the calibration span is considered invalid.

This approach offers several additional advantages. First, it gives the tester flexibility to set the calibration range at a convenient number that is not excessive. Second, it alleviates concern about the quality of data points that are currently allowed between the high calibration concentration and the span. Third, if it is properly chosen with the majority of measurements in the 20-to-100 percent range, it would prevent a tester from choosing an inordinately high calibration range which reduces measurement accuracy.

C. Calibration Drift Test. Commenters generally thought that the between-run calibration drift requirement should not be eliminated as in the proposal. We have taken this recommendation and retained the between-run drift determination.

D. Analyzer Calibration Error Test. Two commenters thought the proposed limit for calibration error of 2 percent of the certified gas concentration was unnecessarily restrictive when compared to the existing 2 percent of span specification. They noted that EPA gave no technical basis for such increased restriction and recommended the proposed

change be dropped. Others wondered why the same gases were required for the analyzer setup and the calibration error test? This seemed redundant.

The proposed requirement that the analyzer calibration error be within 2 percent of the tag value has been changed to 2 percent of the calibration span. The proposed requirement to calibrate the instrument with the same gases used in the calibration error test has been dropped.

E. Interference Test. Commenters in general objected to EPA's proposed requirement to conduct the interference test on an annual basis. They noted that little evidence was provided to show that annual interference testing was necessary. They believed the test should only be repeated after major instrument modifications. Annual interference testing was thought to put a major burden on the testing companies.

The commenters raised valid concerns. The proposed requirement to conduct the interference test on an annual basis has been dropped. The interference test will remain a one-time test except for major instrument modifications, as is the current requirement. The current interference test in Method 6C, where the analyzer is compared to modified Method 6 samples in the field, is now listed as the

alternative interference test procedure since this approach was considered archaic by some commenters. An interference test where the analyzer is challenged by potential interferent gases is now the primary procedure.

F. Alternative Dynamic Spike Procedure. Commenters thought the dynamic spiking procedure was confusing and lacked sufficient detail to perform. Some commenters thought adding the procedure was a good idea; others strenuously objected to even allowing it as an option.

We have retained the allowance to use dynamic spiking as an alternative to the interference and bias tests, except for Part 75 applications, where Administrative approval is required to use the procedure. We purposely made the procedure general and performance-based instead of making it prescriptive because different procedures may be followed to perform it successfully. We believe that dynamic spiking is a valuable tool for evaluating a method and should be retained as an alternative for testers able to perform it. Clarity has been added to the procedure details where possible to remove confusion.

G. Sampling Traverse Points. Comments were mixed on the proposed requirement to use Method 1 unless a stratification test showed fewer sampling point are

justified. The majority did not think a Method 1 determination was justified for gaseous sampling in all cases and that this made the methods burdensome and significantly more costly to use. Others proposed reducing the number of points to three, as are allowed in relative accuracy testing of continuous emission monitoring systems. Two commenters recommended dropping the proposed requirement to correct the pollutant concentration for diluent in the stratification test.

In the final rule, the tester may either sample at twelve Method 1 points or a stratification test (3-point or 12-point) may be performed. If the stratification test is done and results in a concentration deviation of any point from the mean concentration by more than 10 percent, then a minimum of twelve traverse points located according to Method 1 must be sampled. If the concentrations of all stratification test points are less than 10 percent from the mean, the testing may resume using 3 traverse points. If the concentrations at all stratification test points are less than 5 percent from the mean, then single-point testing may be performed. Note that these traverse point layout rules are not intended to apply to relative accuracy test audits (RATA) of continuous emission monitoring

systems (CEMS) where applicable CEMS quality assurance requirements specify specific traverse point selection requirements for RATA.

H. Sampling Dilution Systems. Commenters recommended that EPA specifically state that dilution-based sampling technology is an acceptable technique. These systems have been approved by the Emission Measurement Center (EMC) as alternative method ALT-007 (Use of Dilution Probes with Instrumental Methods). Guidance Document 18 from EMC also indicates that dilution sampling systems are acceptable for use with Methods 6C, 7E, 20, and 10, and the special requirements of dilution-based sampling are addressed. This information, or the discussions found in Chapter 21 of the Part 75 Emissions Monitoring Policy Manual were recommended for addition to the methods.

The instrumental methods have been modified to clearly note that dilution systems are acceptable. We have included discussions of calibration gas needs relative to the sample gas molecular weight, calibration drift test variations, and other instructions pertinent to dilutions systems that were a part of EMC Guidance Document GD-18.

I. Equipment Heating Specifications. Several commenters criticized the numerous references to equipment

heating that were thought to preclude the use of other techniques of preventing sample loss. We were urged to require that the sample be maintained at a temperature above the dew point of the sample gas rather than specifying minimum equipment temperatures to provide a technology-neutral approach.

The language has been changed to allow the tester to choose which procedure or technology to use for preventing condensation. The final rule requires the sample gas be maintained above the dew point of the stack gas (including all gas components, e.g. acid gas constituents) so that no loss of sample results. This may be done by heating, diluting, drying, desiccating, a combination thereof, or by other means.

J. Technology-Specific Analyzers. Various references to specific technologies throughout the methods were noted. Most commenters wanted us to remove these references. One commenter implicated electrochemical cells for providing completely unreliable results when not operated in diffusion limiting conditions even though such analyzers could meet the performance criteria of the proposal while operating outside of diffusion-limiting conditions. The

commenter recommended this technology be subject to special procedures such as those included in ASTM D6522-00.

We have removed the references to specific technologies in the methods to make them flexible and performance-based, not technology-based. It may be difficult to set performance requirements that appropriately evaluate all analytical techniques 100 percent of the time. However, we believe the interference, calibration error, and bias tests provide adequate assessments of performance for the majority of the time. The electrochemical analyzer has been shown capable of producing reliable results in an Environmental Technology Verification study, and we do not believe special restrictions should be placed on this technology.

K. Calibration Gases. Commenters asked that we list all of the allowable calibration gas blends in the methods. They wanted the wording changed to allow the flexibility of blending standards with other gases that can be shown not to interfere. One commenter thought the proposed mid-level calibration gas range of 20 to 70 percent of the span-level gas was an improvement over the existing 40 to 60 percent range. Another commenter thought this would allow for poor selection of mid-level gases. Other commenters wondered if

it was acceptable to prepare calibration gases from a single high-concentration EPA Traceability Protocol gas using Method 205.

Blended calibration gases are allowed in the final rule provided they are made from Traceability Protocol gases and any additional gas components are shown not to interfere with the analysis. After considering the comments, the EPA has decided to retain the current 40-to-60 percent of span requirement for the mid-level gas. We believe this ensures a better evaluation of the analyzer's linear response, as noted by one of the commenters. In the final rule, Method 205 is allowed to prepare calibration gases from high-concentration gases of EPA Traceability Protocol quality, except for Part 75 applications, which require administrative approval to use this technique.

L. Method 7E Converter Test. Several commenters noted that the nitrogen dioxide (NO₂) calibration gas used in the converter efficiency test is not available as an EPA Traceability Protocol Standard as required. This prevents one from performing the test. Because NO₂ has unusual storage problems, it is difficult to maintain the gas at its certified concentration. A search of vendors has shown that gas of traceability protocol quality is available

commercially, but in limited concentrations and from limited sources. We also concur with the long-term stability problems noted with NO₂ cylinder gas. Because of these concerns, we have retained the original procedures cited in Method 20 for determining converter efficiency and have listed the proposed procedure for direct evaluation with NO₂ as an allowable alternative. Numerous commenters pointed out the error in the converter efficiency correction in the uncertainty calculation. This error has been corrected through a new equation.

Commenters generally thought that requiring the converter efficiency gas be in the concentration range of the source emissions was too restrictive and would require numerous gas cylinders be transported into the field. We understand the difficulty in preparing test gases to match anticipated emission levels. Therefore, we have dropped the proposed requirement to match the stack NO₂ concentration within 50 percent and instead require gas in the 40 to 60 ppm range for all cases.

IV. Summary of Environmental, Energy, and Economic Impacts

A. Executive Order 12866: Regulatory Planning and Reviews

Under Executive Order 12866 (58 FR 51735 October 4, 1993), the EPA must determine whether this regulatory

action is "significant" and therefore subject to review by the Office of Management and Budget (OMB) and the requirements of the Executive Order. The Order defines "significant regulatory action" as one that is likely to result in a rule that may: (1) have an annual effect on the economy of \$100 million or more or adversely affects in a material way the economy, a sector of the economy, productivity, competition, jobs, the environment, public health or safety, or State, Local, or Tribal governments or communities; (2) create a serious inconsistency or otherwise interferes with an action taken or planned by another agency; (3) materially alter the budgetary impact of entitlements, grants, user fees, or loan programs, or the rights and obligations of recipients thereof; or (4) raise novel legal or policy issues arising out of legal mandates, the President's priorities, or the principles set forth in the Executive Order.

We have determined that this rule is not a "significant regulatory action" under the terms of Executive Order 12866 and is therefore not subject to OMB review. We have determined that this regulation would result in none of the economic effects set forth in Section 1 of the Order because it does not impose emission measurement

requirements beyond those specified in the current regulations, nor does it change any emission standard.

B. Paperwork Reduction Act

This action does not impose an information collection burden under the provisions of the Paperwork Reduction Act, 44 U.S.C. 3501 et seq. These criteria do not add information collection requirements beyond those currently required under the applicable regulation. The amendments being made to the test methods do not add information collection requirements but make needed updates to existing testing methodology.

Burden means the total time, effort, or financial resources expended by persons to generate, maintain, retain, or disclose or provide information to or for a Federal agency. This includes the time needed to review instructions; develop, acquire, install, and utilize technology and systems for the purposes of collecting, validating, and verifying information, processing and maintaining information, and disclosing and providing information; adjust the existing ways to comply with any previously applicable instructions and requirements; train personnel to be able to respond to a collection of information; search data sources; complete and review the

collection of information; and transmit or otherwise disclose the information.

An agency may not conduct or sponsor, and a person is not required to respond to a collection of information unless it displays a currently valid OMB control number. The OMB control numbers for EPA's regulations in 40 CFR are listed in 40 CFR Part 9.

C. Regulatory Flexibility Act

EPA has determined that it is not necessary to prepare a regulatory flexibility analysis in connection with this final rule.

For purposes of assessing the impacts of today's rule on small entities, small entity is defined as: (1) a small business as defined by the Small Business Administrations' regulations at 13 CFR 121.201; (2) a small governmental jurisdiction that is a government of a city, county, town, school district or special district with a population of less than 50,000; and (3) a small organization that is any not-for-profit enterprise which is independently owned and operated and is not dominant in its field. Entities potentially affected by this action include those listed in Table 1 of SUPPLEMENTARY INFORMATION.

After considering the economic impacts of today's final rule on small entities, I have concluded that this action will not have a significant economic impact on a substantial number of small entities. This rule reflects changes to the proposal to accommodate the public comments and is made to improve the test methods by simplifying, harmonizing, and updating their procedures. A large number of the regulated industries are already subject to the provision that require the use of these methods and this rule does not impose any new emission measurement requirements beyond those specified in the current regulations, nor does it change any emission standard but makes needed updates to existing testing methodology. This rule would also add some flexibility by giving testers more choice in selecting their test equipment which could translate into reduced costs for the regulated industries.

D. Unfunded Mandates Reform Act

Title II of the Unfunded Mandates Reform Act of 1995 (UMRA), P.L. 104-4, establishes requirements for Federal agencies to assess the effects of their regulatory actions on State, Local, and Tribal governments and the private sector. Under section 202 of the UMRA, EPA generally must prepare a written statement, including a cost-benefit

analysis, for proposed and final rules with "Federal mandates" that may result in expenditures to State, Local, and Tribal governments, in the aggregate, or to the private sector, of \$100 million or more in any one year. Before promulgating an EPA rule for which a written statement is needed, section 205 of the UMRA generally requires EPA to identify and consider a reasonable number of regulatory alternatives and adopt the least costly, most cost-effective or least burdensome alternative that achieves the objectives of the rule. The provisions of section 205 do not apply when they are inconsistent with applicable law. Moreover, section 205 allows EPA to adopt an alternative other than the least costly, most cost-effective or least burdensome alternative if the Administrator publishes with the final rule an explanation why that alternative was not adopted. Before EPA establishes any regulatory requirements that may significantly or uniquely affect small governments, including tribal governments, it must have developed under section 203 of the UMRA a small government agency plan. The plan must provide for notifying potentially affected small governments, enabling officials of affected small governments to have meaningful and timely input in the development of EPA regulatory

proposals with significant Federal intergovernmental mandates, and informing, educating, and advising small governments on compliance with the regulatory requirements.

Today's rule contains no Federal mandates (under the regulatory provisions of Title II of the UMRA) for State, Local, or Tribal governments or the private sector. The rule imposes no enforceable duty on any State, Local, or Tribal governments or the private sector. In any event, EPA has determined that this rule does not contain a Federal mandate that may result in expenditures of \$100 million or more for State, Local, and Tribal governments, in the aggregate, or the private sector in any one year. Thus, today's rule is not subject to the requirements of Sections 202 and 205 of the UMRA.

E. Executive Order 13132: Federalism

Executive Order 13132, entitled "Federalism" (64 FR 43255, August 10, 1999), requires EPA to develop an accountable process to ensure "meaningful and timely input by State and Local officials in the development of regulatory policies that have federalism implications." "Policies that have federalism implications" are defined in the Executive Order to include regulations that have "substantial direct effects on the States, on the

relationship between the national government and the States, or on the distribution of power and responsibilities among the various levels of government.”

This rule does not have federalism implications. It will not have substantial direct effects on the States, on the relationship between the national government and the States, or on the distribution of power and responsibilities among the various levels of government, as specified in Executive Order 13132. Thus, the requirements of Section 6 of the Executive Order do not apply to this rule.

F. Executive Order 13175: Consultation and Coordination with Tribal Governments

Executive Order 13175, entitled “Consultation and Coordination with Indian Tribal Governments” (65 FR 67249, November 6, 2000), requires EPA to develop an accountable process to ensure “meaningful and timely input by tribal officials in the development of regulatory policies that have tribal implications.” “Policies that have tribal implications” is defined in the Executive Order to include regulations that have “substantial direct effects on one or more Indian tribes, on the relationship between the Federal government and the Indian tribes, or on the distribution of

power and responsibilities between the Federal government and Indian tribes.”

This final rule does not have tribal implications. It will not have substantial direct effects on tribal governments, on the relationship between the Federal government and Indian tribes, or on the distribution of power and responsibilities between the Federal government and Indian tribes, as specified in Executive Order 13175. In this final rule, we are simply updating existing pollutant test methods. Thus, Executive Order 13175 does not apply to this rule.

G. Executive Order 13045: Protection of Children From Environmental Health Risks and Safety Risks

Executive Order 13045 applies to any rule that EPA determines (1) is "economically significant" as defined under Executive Order 12866, and (2) the environmental health or safety risk addressed by the rule has a disproportionate effect on children. If the regulatory action meets both criteria, the Agency must evaluate the environmental health or safety effects of the planned rule on children and explain why the planned regulation is preferable to other potentially effective and reasonably feasible alternatives considered by the Agency.

The EPA interprets Executive Order 13045 as applying only to regulatory actions that are based on health or safety risks, such that the analysis required under section 5-501 of the Executive Order has the potential to influence the regulation. This final rule is not subject to Executive Order 13045 because it is not based on health or safety risks.

H. Executive Order 13211: Actions Concerning Regulations that Significantly Affect Energy Supply, Distribution, or Use

This action is not subject to Executive Order 13211, "Actions Concerning Regulations that Significantly Affect Energy Supply, Distribution, or Use" (66 FR 28355, May 22, 2001) because it is not a significant regulatory action under Executive Order 12866.

I. NTTAA: National Technology Transfer and Advancement Act

Section 12(d) of the National Technology Transfer and Advancement Act of 1995 (NTTAA), P.L. 104-113 (15 U.S.C. 272), directs us to use voluntary consensus standards (VCS) in our regulatory activities unless to do so would be inconsistent with applicable law or otherwise impractical. Voluntary consensus standards are technical standards (e.g., materials specifications, test methods, sampling

procedures, business practices, etc.) that are developed or adopted by VCS bodies. The NTTAA requires us to provide Congress, through OMB, explanations when we decide not to use available and applicable VCS. We are requiring new test methods in this rulemaking. Therefore, NTTAA does not apply.

J. Congressional Review Act

The Congressional Review Act, 5 U.S.C. 801 et seq., as added by the Small Business Regulatory Enforcement Fairness Act of 1996, generally provides that before a rule may take effect, the agency promulgating the rule must submit a rule report, which includes a copy of the rule, to each House of the Congress and to the Comptroller General of the United States. The EPA will submit a report containing the final rule amendments and other required information to the U.S. Senate, the U.S. House of Representatives, and the Comptroller General of the United States prior to publication of the final rule amendments in the Federal Register. A major rule cannot take effect until 60 days after its publication in the Federal Register. This action is not a "major rule" as defined by 5 U.S.C. 804(2). The final rule amendments will be effective on [INSERT DATE 60

DAYS AFTER PUBLICATION OF THE FINAL RULE IN THE FEDERAL REGISTER].

List of Subjects in 40 CFR Part 60

Environmental protection, Air pollution control, New sources, Test methods and procedures, Performance specifications, and Continuous emission monitors.

Dated:

Stephen L. Johnson,
Administrator.

For the reasons stated in the preamble, title 40, chapter I, Part 60 of the Code of Federal Regulations is amended as follows:

Part 60 - - [AMENDED]

1. The authority citation for Part 60 continues to read as follows:

Authority: 42 U.S.C. 7401 et seq.

2. Appendix A-2 is amended by revising Method 3A to read as follows:

Appendix A-2 to Part 60 - Test Methods 2G through 3C

* * * * *

**METHOD 3A - DETERMINATION OF OXYGEN AND CARBON DIOXIDE
CONCENTRATIONS IN EMISSIONS FROM STATIONARY SOURCES**

(INSTRUMENTAL ANALYZER PROCEDURE)

1.0 Scope and Application

What is Method 3A?

Method 3A is a procedure for measuring oxygen (O₂) and carbon dioxide (CO₂) in stationary source emissions using a continuous instrumental analyzer. Quality assurance and quality control requirements are included to assure that you, the tester, collect data of known quality. You must document your adherence to these specific requirements for

equipment, supplies, sample collection and analysis, calculations, and data analysis.

This method does not completely describe all equipment, supplies, and sampling and analytical procedures you will need but refers to other methods for some of the details. Therefore, to obtain reliable results, you should also have a thorough knowledge of these additional test methods which are found in appendix A to this part:

- (a) Method 1—Sample and Velocity Traverses for Stationary Sources.
- (b) Method 3—Gas Analysis for the Determination of Molecular Weight.
- (c) Method 4—Determination of Moisture Content in Stack Gases.
- (d) Method 7E—Determination of Nitrogen Oxides Emissions from Stationary Sources (Instrumental Analyzer Procedure).

1.1 Analytes. **What does this method determine?** This method measures the concentration of oxygen and carbon dioxide.

Analyte	CAS No.	Sensitivity
Oxygen (O ₂)	7782-44-7	Typically <2% of Calibration Span
Carbon dioxide (CO ₂)	124-38-9	Typically <2% of Calibration Span

1.2 Applicability. **When is this method required?**

The use of Method 3A may be required by specific New Source Performance Standards, Clean Air Marketing rules, State Implementation Plans and permits, where measurements of O₂ and CO₂ concentrations in stationary source emissions must be made, either to determine compliance with an applicable emission standard or to conduct performance testing of a continuous emission monitoring system (CEMS). Other regulations may also require the use of Method 3A.

1.3 Data Quality Objectives. **How good must my collected data be?** Refer to Section 1.3 of Method 7E.

2.0 Summary of Method

In this method, you continuously or intermittently sample the effluent gas and convey the sample to an analyzer that measures the concentration of O₂ or CO₂. You must meet the performance requirements of this method to validate your data.

3.0 Definitions

Refer to Section 3.0 of Method 7E for the applicable definitions.

4.0 Interferences [Reserved]

5.0 Safety

Refer to Section 5.0 of Method 7E.

6.0 Equipment and Supplies

Figure 7E-1 in Method 7E is a schematic diagram of an acceptable measurement system.

6.1 What do I need for the measurement system? The components of the measurement system are described (as applicable) in Sections 6.1 and 6.2 of Method 7E, except that the analyzer described in Section 6.2 of this method must be used instead of the analyzer described in Method 7E. You must follow the noted specifications in Section 6.1 of Method 7E except that the requirements to use stainless steel, Teflon, or non-reactive glass filters do not apply. Also, a heated sample line is not required to transport dry gases or for systems that measure the O₂ or CO₂ concentration on a dry basis, provided that the system is not also being used to concurrently measure SO₂ and/or NO_x.

6.2 What analyzer must I use? You must use an analyzer that continuously measures O₂ or CO₂ in the gas stream and meets the specifications in Section 13.0.

7.0 Reagents and Standards

7.1 Calibration Gas. What calibration gases do I need? Refer to Section 7.1 of Method 7E for the

calibration gas requirements. Example calibration gas mixtures are listed below.

- (a) CO₂ in nitrogen (N₂).
- (b) CO₂ in air.
- (c) CO₂/SO₂ gas mixture in N₂.
- (d) O₂/SO₂ gas mixture in N₂.
- (e) O₂/CO₂/SO₂ gas mixture in N₂.
- (f) CO₂/NO_x gas mixture in N₂
- (g) CO₂/SO₂/NO_x gas mixture in N₂

The tests for analyzer calibration error and system bias require high-, mid-, and low-level gases.

7.2 Interference Check. **What reagents do I need for the interference check?**

Potential interferences may vary among available analyzers. Table 7E-3 of Method 7E lists a number of gases that should be considered in conducting the interference test.

8.0 Sample Collection, Preservation, Storage, and Transport

8.1 Sampling Site and Sampling Points. You must follow the procedures of Section 8.1 of Method 7E to determine the appropriate sampling points, unless you are using Method 3A only to determine the stack gas molecular weight and for no other purpose. In that case, you may use

single-point integrated sampling as described in Section 8.2 of Method 3. If the stratification test provisions in Section 8.1.2 of Method 7E are used to reduce the number of required sampling points, the alternative acceptance criterion for 3-point sampling will be ± 0.5 percent CO₂ or O₂, and the alternative acceptance criterion for single-point sampling will be ± 0.3 percent CO₂ or O₂.

8.2 Initial Measurement System Performance Tests.

You must follow the procedures in Section 8.2 of Method 7E. If a dilution-type measurement system is used, the special considerations in Section 8.3 of Method 7E apply.

8.3 Interference Check. The O₂ or CO₂ analyzer must be documented to show that interference effects do not exceed 2.5 percent of the calibration span. The interference test in Section 8.2.7 of Method 7E is a procedure that may be used to show this. The effects of all potential interferences at the concentrations encountered during testing must be addressed and documented. This testing and documentation may be done by the instrument manufacturer.

8.4 Sample Collection. You must follow the procedures in Section 8.4 of Method 7E.

8.5 Post-Run System Bias Check and Drift Assessment.

You must follow the procedures in Sections 8.5 of Method 7E.

9.0 Quality Control

Follow quality control procedures in Section 9.0 of Method 7E.

10.0 Calibration and Standardization

Follow the procedures for calibration and standardization in Section 10.0 of Method 7E.

11.0 Analytical Procedures

Because sample collection and analysis are performed together (see Section 8), additional discussion of the analytical procedure is not necessary.

12.0 Calculations and Data Analysis

You must follow the applicable procedures for calculations and data analysis in Section 12.0 of Method 7E, substituting percent O₂ and percent CO₂ for ppmv of NO_x as appropriate.

13.0 Method Performance

The specifications for the applicable performance checks are the same as in Section 13.0 of Method 7E except for the alternative specifications for system bias, drift, and calibration error. In these alternative

specifications, replace the term "0.5 ppmv" with the term "0.5 percent O₂" or "0.5 percent CO₂" (as applicable).

14.0 Pollution Prevention [Reserved]

15.0 Waste Management [Reserved]

16.0 Alternative Procedures [Reserved]

17.0 References

1. "EPA Traceability Protocol for Assay and Certification of Gaseous Calibration Standards" September 1997 as amended, EPA-600/R-97/121

18.0 Tables, Diagrams, Flowcharts, and Validation Data

Refer to Section 18.0 of Method 7E.

* * * * *

3. Appendix A-4 is amended by revising Methods 6C, 7E, and 10 to read as follows:

Appendix A-4 to Part 60 - Test Methods 6 through 10B

* * * * *

METHOD 6C - DETERMINATION OF SULFUR DIOXIDE EMISSIONS

FROM STATIONARY SOURCES

(INSTRUMENTAL ANALYZER PROCEDURE)

1.0 Scope and Application

What is Method 6C?

Method 6C is a procedure for measuring sulfur dioxide (SO₂) in stationary source emissions using a continuous instrumental analyzer. Quality assurance and quality control requirements are included to assure that you, the tester, collect data of known quality. You must document your adherence to these specific requirements for equipment, supplies, sample collection and analysis, calculations, and data analysis.

This method does not completely describe all equipment, supplies, and sampling and analytical procedures you will need but refers to other methods for some of the details. Therefore, to obtain reliable results, you should also have a thorough knowledge of these additional test methods which are found in appendix A to this part:

(a) Method 1—Sample and Velocity Traverses for Stationary Sources.

(b) Method 4—Determination of Moisture Content in Stack Gases.

(c) Method 6—Determination of Sulfur Dioxide Emissions from Stationary Sources.

(d) Method 7E—Determination of Nitrogen Oxides Emissions from Stationary Sources (Instrumental Analyzer Procedure).

1.1 Analytes. **What does this method determine?** This method measures the concentration of sulfur dioxide.

Analyte	CAS No.	Sensitivity
SO ₂	7446-09-5	Typically <2% of Calibration Span

1.2 Applicability. **When is this method required?**

The use of Method 6C may be required by specific New Source Performance Standards, Clean Air Marketing rules, State Implementation Plans, and permits where SO₂ concentrations in stationary source emissions must be measured, either to determine compliance with an applicable emission standard or to conduct performance testing of a continuous emission

monitoring system (CEMS). Other regulations may also require the use of Method 6C.

1.3 Data Quality Objectives. **How good must my collected data be?** Refer to Section 1.3 of Method 7E.

2.0 Summary of Method

In this method, you continuously sample the effluent gas and convey the sample to an analyzer that measures the concentration of SO₂. You must meet the performance requirements of this method to validate your data.

3.0 Definitions

Refer to Section 3.0 of Method 7E for the applicable definitions.

4.0 Interferences

Refer to Section 4.1 of Method 6.

5.0 Safety

Refer to Section 5.0 of Method 7E.

6.0 Equipment and Supplies

Figure 7E-1 of Method 7E is a schematic diagram of an acceptable measurement system.

6.1 **What do I need for the measurement system?** The essential components of the measurement system are the same as those in Sections 6.1 and 6.2 of Method 7E, except that the SO₂ analyzer described in Section 6.2 of this method

must be used instead of the analyzer described in Section 6.2 of Method 7E. You must follow the noted specifications in Section 6.1 of Method 7E.

6.2 What analyzer must I use? You may use an instrument that uses an ultraviolet, non-dispersive infrared, fluorescence, or other detection principle to continuously measure SO₂ in the gas stream and meets the performance specifications in Section 13.0. The low-range and dual-range analyzer provisions in Section 6.2.8.1 of Method 7E apply.

7.0 Reagents and Standards

7.1 Calibration Gas. What calibration gases do I need? Refer to Section 7.1 of Method 7E for the calibration gas requirements. Example calibration gas mixtures are listed below.

- (a) SO₂ in nitrogen (N₂).
- (b) SO₂ in air.
- (c) SO₂ and CO₂ in N₂.
- (d) SO₂ and O₂ in N₂.
- (e) SO₂/CO₂/O₂ gas mixture in N₂.
- (f) CO₂/NO_x gas mixture in N₂
- (g) CO₂/SO₂/NO_x gas mixture in N₂

7.2 Interference Check. **What additional reagents do I need for the interference check?** The test gases for the interference check are listed in Table 7E-3 of Method 7E. For the alternative interference check, you must use the reagents described in Section 7.0 of Method 6.

8.0 Sample Collection, Preservation, Storage, and Transport

8.1 Sampling Site and Sampling Points. You must follow the procedures of Section 8.1 of Method 7E.

8.2 Initial Measurement System Performance Tests. You must follow the procedures in Section 8.2 of Method 7E. If a dilution-type measurement system is used, the special considerations in Section 8.3 of Method 7E also apply.

8.3 Interference Check. You must follow the procedures of Section 8.2.7 of Method 7E to conduct an interference check, substituting SO₂ for NO_x as the method pollutant. For dilution-type measurement systems, you must use the alternative interference check procedure in Section 16 and a co-located, unmodified Method 6 sampling train.

8.4 Sample Collection. You must follow the procedures of Section 8.4 of Method 7E.

8.5 Post-Run System Bias Check and Drift Assessment. You must follow the procedures of Section 8.5 of Method 7E.

9.0 Quality Control

Follow quality control procedures in Section 9.0 of Method 7E.

10.0 Calibration and Standardization

Follow the procedures for calibration and standardization in Section 10.0 of Method 7E.

11.0 Analytical Procedures

Because sample collection and analysis are performed together (see Section 8), additional discussion of the analytical procedure is not necessary.

12.0 Calculations and Data Analysis

You must follow the applicable procedures for calculations and data analysis in Section 12.0 of Method 7E as applicable, substituting SO₂ for NO_x as appropriate.

13.0 Method Performance

13.1 The specifications for the applicable performance checks are the same as in Section 13.0 of Method 7E.

13.2 Alternative Interference Check. The results are acceptable if the difference between the Method 6C result and the modified Method 6 result is less than 7.0 percent of the Method 6 result for each of the three test runs.

For the purposes of comparison, the Method 6 and 6C results must be expressed in the same units of measure.

14.0 Pollution Prevention [Reserved]

15.0 Waste Management [Reserved]

16.0 Alternative Procedures

16.1 Alternative Interference Check. You may perform an alternative interference check consisting of at least three comparison runs between Method 6C and Method 6. This check validates the Method 6C results at each particular facility of known potential interferences. When testing under conditions of low concentrations (< 15 ppm), this alternative interference check is not allowed. **Note:** The procedure described below applies to non-dilution sampling systems only. If this alternative interference check is used for a dilution sampling system, use a standard Method 6 sampling train and extract the sample directly from the exhaust stream at points collocated with the Method 6C sample probe.

(1) Build the modified Method 6 sampling train (flow control valve, two midget impingers containing 3 percent hydrogen peroxide, and dry gas meter) shown in Figure 6C-1. Connect the sampling train to the sample bypass discharge vent. Record the dry gas meter reading before you begin

sampling. Simultaneously collect modified Method 6 and Method 6C samples. Open the flow control valve in the modified Method 6 train as you begin to sample with Method 6C. Adjust the Method 6 sampling rate to 1 liter per minute (.10 percent). The sampling time per run must be the same as for Method 6 plus twice the average measurement system response time. If your modified Method 6 train does not include a pump, you risk biasing the results high if you over-pressurize the midget impingers and cause a leak. You can reduce this risk by cautiously increasing the flow rate as sampling begins.

(2) After completing a run, record the final dry gas meter reading, meter temperature, and barometric pressure. Recover and analyze the contents of the midget impingers using the procedures in Method 6. You must analyze performance audit samples as described in Method 6 with this interference check. Determine the average gas concentration reported by Method 6C for the run.

17.0 References

1. "EPA Traceability Protocol for Assay and Certification of Gaseous Calibration Standards" September 1997 as amended, EPA-600/R-97/121

18.0 Tables, Diagrams, Flowcharts, and Validation Data

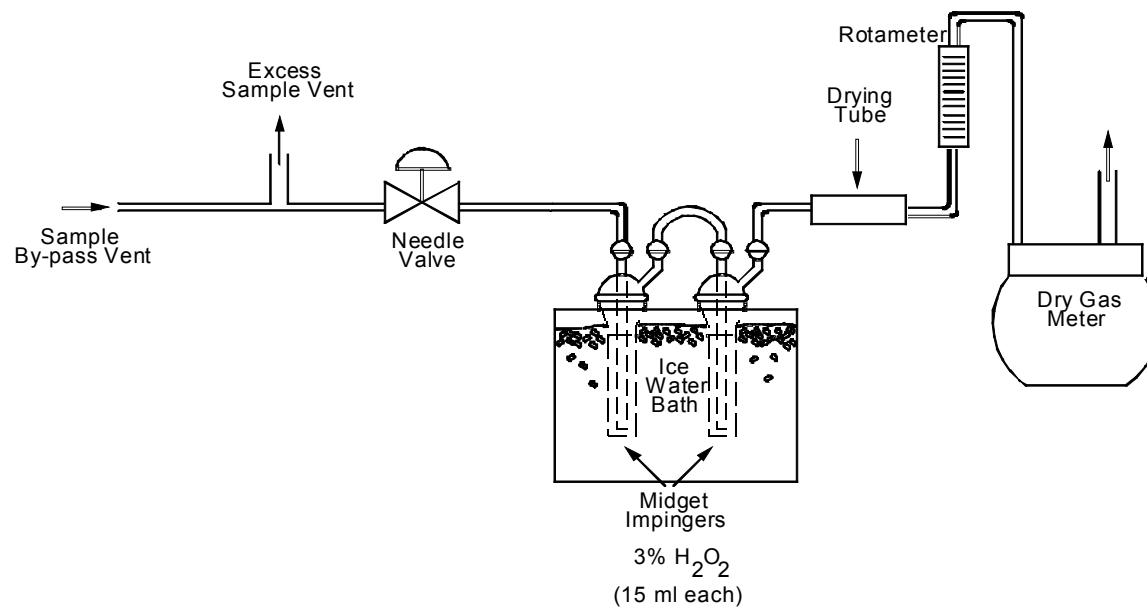

**Figure 6C-1. Modified Method 6
Alternative Interference Check Sampling Train**

* * * * *

* * * * *

**METHOD 7E - DETERMINATION OF NITROGEN OXIDES EMISSIONS FROM
STATIONARY SOURCES
(INSTRUMENTAL ANALYZER PROCEDURE)**

1.0 Scope and Application

What is Method 7E?

Method 7E is a procedure for measuring nitrogen oxides (NO_x) in stationary source emissions using a continuous instrumental analyzer. Quality assurance and quality control requirements are included to assure that you, the tester, collect data of known quality. You must document your adherence to these specific requirements for equipment, supplies, sample collection and analysis, calculations, and data analysis. This method does not completely describe all equipment, supplies, and sampling and analytical procedures you will need but refers to other methods for some of the details. Therefore, to obtain reliable results, you should also have a thorough knowledge of these additional test methods which are found in appendix A to this part:

(a) Method 1—Sample and Velocity Traverses for Stationary Sources.

(b) Method 4—Determination of Moisture Content in Stack Gases.

1.1 Analytes. **What does this method determine?** This method measures the concentration of nitrogen oxides as NO₂.

Analyte	CAS No.	Sensitivity
Nitric oxide (NO)	10102-43-9	Typically <2% of Calibration Span
Nitrogen dioxide (NO ₂)	10102-44-0	

1.2 Applicability. **When is this method required?**

The use of Method 7E may be required by specific New Source Performance Standards, Clean Air Marketing rules, State Implementation Plans, and permits where measurement of NO_x concentrations in stationary source emissions is required, either to determine compliance with an applicable emissions standard or to conduct performance testing of a continuous monitoring system (CEMS). Other regulations may also require the use of Method 7E.

1.3 Data Quality Objectives (DQO). **How good must my collected data be?** Method 7E is designed to provide high-quality data for determining compliance with Federal and State emission standards and for relative accuracy testing

of CEMS. In these and other applications, the principal objective is to ensure the accuracy of the data at the actual emission levels encountered. To meet this objective, the use of EPA traceability protocol calibration gases and measurement system performance tests are required.

1.4 Data Quality Assessment for Low Emitters. **Is performance relief granted when testing low-emission units?**

Yes. For low-emitting sources, there are alternative performance specifications for analyzer calibration error, system bias, drift, and response time. Also, the alternative dynamic spiking procedure in Section 16 may provide performance relief for certain low-emitting units.

2.0 Summary of Method

In this method, a sample of the effluent gas is continuously sampled and conveyed to the analyzer for measuring the concentration of NO_x. You may measure NO and NO₂ separately or simultaneously together but, for the purposes of this method, NO_x is the sum of NO and NO₂. You must meet the performance requirements of this method to validate your data.

3.0 Definitions

3.1 *Analyzer Calibration Error*, for non-dilution systems, means the difference between the manufacturer certified concentration of a calibration gas and the measured concentration of the same gas when it is introduced into the analyzer in direct calibration mode.

3.2 *Calibration Curve* means the relationship between an analyzer's response to the injection of a series of calibration gases and the actual concentrations of those gases.

3.3 *Calibration Gas* means the gas mixture containing NO_x at a known concentration and produced and certified in accordance with "EPA Traceability Protocol for Assay and Certification of Gaseous Calibration Standards," September 1997, as amended August 25, 1999, EPA-600/R-97/121 or more recent updates. The tests for analyzer calibration error, drift, and system bias require the use of calibration gas prepared according to this protocol.

3.3.1 *Low-Level Gas* means a calibration gas with a concentration that is less than 20 percent of the calibration span and may be a zero gas.

3.3.2 *Mid-Level Gas* means a calibration gas with a concentration that is 40 to 60 percent of the calibration span.

3.3.3 *High-Level Gas* means a calibration gas with a concentration that is equal to the calibration span.

3.4 *Calibration Span* means the upper limit of valid instrument response during sampling. To the extent practicable, the measured emissions should be between 20 to 100 percent of the selected calibration span

3.5 *Centroidal Area* means the central area of the stack or duct that is no greater than 1 percent of the stack or duct cross section. This area has the same geometric shape as the stack or duct.

3.6 *Converter Efficiency Gas* means a calibration gas with a known NO or NO₂ concentration and of Traceability Protocol quality.

3.7 *Data Recorder* means the equipment that permanently records the concentrations reported by the analyzer.

3.8 *Direct Calibration Mode* means introducing the calibration gases directly into the analyzer (or into the assembled measurement system at a point downstream of all sample conditioning equipment) according to manufacturer's recommended calibration procedure. This mode of calibration applies to non-dilution-type measurement systems.

3.9 *Drift* means the difference between the measurement system readings obtained in the pre-run and post-run system bias (or system calibration error) checks at a specific calibration gas concentration level (i.e. low-, mid-, or high-).

3.10 *Gas Analyzer* means the equipment that senses the gas being measured and generates an output proportional to its concentration.

3.11 *Interference Check* means the test to detect analyzer responses to compounds other than the compound of interest, usually a gas present in the measured gas stream, that is not adequately accounted for in the calibration procedure and may cause measurement bias.

3.12 *Low-Concentration Analyzer* means any analyzer that operates with a calibration span of 20 ppm NO_x or lower. Each analyzer model used routinely to measure low NO_x concentrations must pass a Manufacturer's Stability Test (MST). A MST subjects the analyzer to a range of potential effects to demonstrate its stability following the procedures provided in 40 CFR 53.23, 53.55, and 53.56 and provides the information in a summary format. A copy of this information must be included in each test report. Table 7E-5 lists the criteria to be met.

3.13 *Measurement System* means all of the equipment used to determine the NO_x concentration. The measurement system comprises six major subsystems: sample acquisition, sample transport, sample conditioning, calibration gas manifold, gas analyzer, and data recorder.

3.14 *Response Time* means the time it takes the measurement system to respond to a change in gas concentration occurring at the sampling point when the system is operating normally at its target sample flow rate or dilution ratio.

3.15 *Run* means a series of gas samples taken successively from the stack or duct. A test normally consists of a specific number of runs.

3.16 *System Bias* means the difference between a calibration gas measured in direct calibration mode and in system calibration mode. System bias is determined before and after each run at the low- and mid- or high-concentration levels. For dilution-type systems, pre- and post-run system calibration error is measured, rather than system bias.

3.17 *System Calibration Error* applies to dilution-type systems and means the difference between the measured concentration of low-, mid-, or high-level calibration gas

and the certified concentration for each gas when introduced in system calibration mode. For dilution-type systems, a 3-point system calibration error test is conducted in lieu of the analyzer calibration error test, and 2-point system calibration error tests are conducted in lieu of system bias tests.

3.18 *System Calibration Mode* means introducing the calibration gases into the measurement system at the probe, upstream of the filter and all sample conditioning components.

3.19 *Test* refers to the series of runs required by the applicable regulation.

4.0 Interferences

Note that interferences may vary among instruments and that instrument-specific interferences must be evaluated through the interference test.

5.0 Safety

What safety measures should I consider when using this method? This method may require you to work with hazardous materials and in hazardous conditions. We encourage you to establish safety procedures before using the method. Among other precautions, you should become familiar with the safety recommendations in the gas analyzer user's manual.

Occupational Safety and Health Administration (OSHA) regulations concerning cylinder and noxious gases may apply. Nitric oxide and NO₂ are toxic and dangerous gases. Nitric oxide is immediately converted to NO₂ upon reaction with air. Nitrogen dioxide is a highly poisonous and insidious gas. Inflammation of the lungs from exposure may cause only slight pain or pass unnoticed, but the resulting edema several days later may cause death. A concentration of 100 ppm is dangerous for even a short exposure, and 200 ppm may be fatal. Calibration gases must be handled with utmost care and with adequate ventilation. Emission-level exposure to these gases should be avoided.

6.0 Equipment and Supplies

The performance criteria in this method will be met or exceeded if you are properly using equipment designed for this application.

6.1 **What do I need for the measurement system?** You may use any equipment and supplies meeting the following specifications.

(1) Sampling system components that are not evaluated in the system bias or system calibration error test must be glass, Teflon, or stainless steel. Other materials are

potentially acceptable, subject to approval by the Administrator.

2) The interference, calibration error, and system bias criteria must be met.

3) Sample flow rate must be maintained within 10 percent of the flow rate at which the system response time was measured.

4) All system components (excluding sample conditioning components, if used) must maintain the sample temperature above the moisture dew point.

Section 6.2 provides example equipment specifications for a NO_x measurement system. Figure 7E-1 is a diagram of an example dry basis measurement system that is likely to meet the method requirements and is provided as guidance. For wet-basis systems, you may use alternative equipment and supplies as needed (some of which are described in Section 6.2), provided that the measurement system meets the applicable performance specifications of this method.

6.2 Measurement System Components

6.2.1 Sample Probe. Glass, stainless steel, or other approved material, of sufficient length to traverse the sample points.

6.2.2 Particulate Filter. An in-stack or out-of-stack filter. The filter media must be included in the system bias test and made of material that is non-reactive to the gas being sampled. This particulate filter requirement may be waived in applications where no significant particulate matter is expected (e.g., for emission testing of a combustion turbine firing natural gas).

6.2.3 Sample Line. The sample line from the probe to the conditioning system/sample pump should be made of Teflon or other material that does not absorb or otherwise alter the sample gas. For a dry-basis measurement system (as shown in Figure 7E-1), the temperature of the sample line must be maintained at a sufficiently high level to prevent condensation before the sample conditioning components. For wet-basis measurement systems, the temperature of the sample line must be maintained at a sufficiently high level to prevent condensation before the analyzer.

6.2.4 Conditioning Equipment. For dry basis measurements, a condenser, dryer or other suitable device is required to remove moisture continuously from the sample gas. Any equipment needed to heat the probe or sample line

to avoid condensation prior to the sample conditioning component is also required.

For wet basis systems, you must keep the sample above its dew point either by: (1) heating the sample line and all sample transport components up to the inlet of the analyzer (and, for hot-wet extractive systems, also heating the analyzer) or (2) by diluting the sample prior to analysis using a dilution probe system. The components required to do either of the above are considered to be conditioning equipment.

6.2.5 Sampling Pump. For systems similar to the one shown in Figure 7E-1, a leak-free pump is needed to pull the sample gas through the system at a flow rate sufficient to minimize the response time of the measurement system. The pump may be constructed of any material that is non-reactive to the gas being sampled. For dilution-type measurement systems, an ejector pump (eductor) is used to create a vacuum that draws the sample through a critical orifice at a constant rate.

6.2.6 Calibration Gas Manifold. Prepare a system to allow the introduction of calibration gases either directly to the gas analyzer in direct calibration mode or into the measurement system, at the probe, in system calibration

mode, or both, depending upon the type of system used. In system calibration mode, the system should be able to block the sample gas flow and flood the sampling probe.

Alternatively, calibration gases may be introduced at the calibration valve following the probe. Maintain a constant pressure in the gas manifold. For in-stack dilution-type systems, a gas dilution subsystem is required to transport large volumes of purified air to the sample probe and a probe controller is needed to maintain the proper dilution ratio.

6.2.7 Sample Gas Manifold. For the type of system shown in Figure 7E-1, the sample gas manifold diverts a portion of the sample to the analyzer, delivering the remainder to the by-pass discharge vent. The manifold should also be able to introduce calibration gases directly to the analyzer (except for dilution-type systems). The manifold must be made of material that is non-reactive to the gas sampled or the calibration gas and be configured to safely discharge the bypass gas.

6.2.8 NO_x Analyzer. An instrument that continuously measures NO_x in the gas stream and meets the applicable specifications in Section 13.0. An analyzer that operates on the principle of chemiluminescence with an NO₂ to NO

converter is one example of an analyzer that has been used successfully in the past. Analyzers operating on other principles may also be used provided the performance criteria in Section 13.0 are met.

6.2.8.1 Dual Range Analyzers. For certain applications, a wide range of gas concentrations may be encountered, necessitating the use of two measurement ranges. Dual-range analyzers are readily available for these applications. These analyzers are often equipped with automated range-switching capability, so that when readings exceed the full-scale of the low measurement range, they are recorded on the high range. As an alternative to using a dual-range analyzer, you may use two segments of a single, large measurement scale to serve as the low and high ranges. In all cases, when two ranges are used, you must quality-assure both ranges using the proper sets of calibration gases. You must also meet the interference, calibration error, system bias, and drift checks. However, we caution that when you use two segments of a large measurement scale for dual range purposes, it may be difficult to meet the performance specifications on the low range due to signal-to-noise ratio considerations.

6.2.8.2 Low Concentration Analyzer. When the calibration span is less than or equal to 20 ppmv, the manufacturer's stability test (MST) is required. See Table 7E-5.

6.2.9 Data Recording. A strip chart recorder, computerized data acquisition system, digital recorder, or data logger for recording measurement data may be used.

7.0 Reagents and Standards

7.1 Calibration Gas. **What calibration gases do I need?** Your calibration gas must be NO in nitrogen and certified (or recertified) within an uncertainty of 2.0 percent in accordance with "EPA Traceability Protocol for Assay and Certification of Gaseous Calibration Standards" September 1997, as amended August 25, 1999, EPA-600/R-97/121. Blended gases meeting the Traceability Protocol are allowed if the additional gas components are shown not to interfere with the analysis. The calibration gas must not be used after its expiration date.

Except for applications under part 75 of this chapter, it is acceptable to prepare calibration gas mixtures from EPA Traceability Protocol gases in accordance with Method 205 in M to part 51 of this chapter. For part 75 applications, the use of Method 205 is subject to the

approval of the Administrator. The goal and recommendation for selecting calibration gases is to bracket the sample concentrations.

The following calibration gas concentrations are required:

7.1.1 *High-Level Gas*. This concentration sets the calibration span and results in measurements being 20 to 100 percent of the calibration span.

7.1.2 *Mid-Level Gas*. 40 to 60 percent of the calibration span.

7.1.3 *Low-Level Gas*. Less than 20 percent of the calibration span.

7.1.4 *Converter Efficiency Gas*. **What reagents do I need for the converter efficiency test?** The converter efficiency gas for the test described in Section 8.2.4.1 must have a concentration of NO₂ that is between 40 and 60 ppmv. For the alternative converter efficiency tests in Section 16.2, NO is required. In either case, the test gas must be prepared according to the EPA Traceability Protocol.

7.2 Interference Check. **What reagents do I need for the interference check?** Use the appropriate test gases listed in Table 7E-3 (i.e., the potential interferents for

the test facility, as identified by the instrument manufacturer) to conduct the interference check.

8.0 Sample Collection, Preservation, Storage, and Transport

Emission Test Procedure

Since you are allowed to choose different options to comply with some of the performance criteria, it is your responsibility to identify the specific options you have chosen, to document that the performance criteria for that option have been met, and to identify any deviations from the method.

8.1 What sampling site and sampling points do I select?

8.1.1 Unless otherwise specified in an applicable regulation or by the Administrator, when this method is used to determine compliance with an emission standard, conduct a stratification test as described in Section 8.1.2 to determine the sampling traverse points to be used. For performance testing of continuous emission monitoring systems, follow the sampling site selection and traverse point layout procedures described in the appropriate performance specification or applicable regulation (e.g., Performance Specification 2 in appendix B to this part).

8.1.2 Determination of Stratification. To test for stratification, use a probe of appropriate length to measure the NO_x (or pollutant of interest) concentration at twelve traverse points located according to Table 1-1 or Table 1-2 of Method 1. Alternatively, you may measure at three points on a line passing through the centroidal area. Space the three points at 16.7, 50.0, and 83.3 percent of the measurement line. Sample for a minimum of twice the system response time (see Section 8.2.6) at each traverse point. Calculate the individual point and mean NO_x concentrations. If the concentration at each traverse point differs from the mean concentration for all traverse points by no more than: (a) ± 5.0 percent of the mean concentration; or (b) ± 0.5 ppm (whichever is less restrictive), the gas stream is considered unstratified and you may collect samples from a single point that most closely matches the mean. If the 5.0 percent or 0.5 ppm criterion is not met, but the concentration at each traverse point differs from the mean concentration for all traverse points by no more than: (a) ± 10.0 percent of the mean; or (b) ± 1.0 ppm (whichever is less restrictive), the gas stream is considered to be minimally stratified, and you may take samples from three points. Space the three

points at 16.7, 50.0, and 83.3 percent of the measurement line. Alternatively, if a twelve point stratification test was performed and the emissions shown to be minimally stratified (all points within ± 10.0 percent of their mean or within ± 1.0 ppm), and if the stack diameter (or equivalent diameter, for a rectangular stack or duct) is greater than 2.4 meters (7.8 ft), then you may use 3-point sampling and locate the three points along the measurement line exhibiting the highest average concentration during the stratification test, at 0.4, 1.0 and 2.0 meters from the stack or duct wall. If the gas stream is found to be stratified because the 10.0 percent or 1.0 ppm criterion for a 3-point test is not met, locate twelve traverse points for the test in accordance with Table 1-1 or Table 1-2 of Method 1.

8.2 Initial Measurement System Performance Tests.

What initial performance criteria must my system meet before I begin collecting samples? Before measuring emissions, perform the following procedures:

- (a) Calibration gas verification,
- (b) Measurement system preparation,
- (c) Calibration error test,

(d) NO₂ to NO conversion efficiency test, if applicable,

(e) System bias check,

(f) System response time test, and

(g) Interference check

8.2.1 Calibration Gas Verification. **How must I verify the concentrations of my calibration gases?** Obtain a certificate from the gas manufacturer and confirm that the documentation includes all information required by the Traceability Protocol. Confirm that the manufacturer certification is complete and current. Ensure that your calibration gases certifications have not expired. This documentation should be available on-site for inspection. To the extent practicable, select a high-level gas concentration that will result in the measured emissions being between 20 and 100 percent of the calibration span.

8.2.2 Measurement System Preparation. **How do I prepare my measurement system?** Assemble, prepare, and precondition the measurement system according to your standard operating procedure. Adjust the system to achieve the correct sampling rate or dilution ratio (as applicable).

8.2.3 Calibration Error Test. **How do I confirm my analyzer calibration is correct?** After you have assembled, prepared and calibrated your sampling system and analyzer, you must conduct a 3-point analyzer calibration error test (or a 3-point system calibration error test for dilution systems) before the first run and again after any failed system bias test (or 2-point system calibration error test for dilution systems) or failed drift test. Introduce the low-, mid-, and high-level calibration gases sequentially. For non-dilution-type measurement systems, introduce the gases in direct calibration mode. For dilution-type measurement systems, introduce the gases in system calibration mode.

(1) For non-dilution systems, you may adjust the system to maintain the correct flow rate at the analyzer during the test, but you may not make adjustments for any other purpose. For dilution systems, you must operate the measurement system at the appropriate dilution ratio during all system calibration error checks, and may make only the adjustments necessary to maintain the proper ratio.

(2) Record the analyzer's response to each calibration gas on a form similar to Table 7E-1. For each calibration gas, calculate the analyzer calibration error

using Equation 7E-1 in Section 12.2 or the system calibration error using Equation 7E-3 in Section 12.4 (as applicable). The calibration error specification in Section 13.1 must be met for the low-, mid-, and high-level gases. If the calibration error specification is not met, take corrective action and repeat the test until an acceptable 3-point calibration is achieved.

8.2.4 NO₂ to NO Conversion Efficiency Test. Before each field test, you must conduct an NO₂ to NO conversion efficiency test if your system converts NO₂ to NO before analyzing for NO_x. Follow the procedures in Section 8.2.4.1, or 8.2.4.2. If desired, the converter efficiency factor derived from this test may be used to correct the test results for converter efficiency if the NO₂ fraction in the measured test gas is known. Use Equation 7E-8 in Section 12.8 for this correction.

8.2.4.1 Introduce a concentration of 40 to 60 ppmv NO₂ to the analyzer in direct calibration mode and record the NO_x concentration displayed by the analyzer. If a dilution-system is used, introduce the NO₂ calibration gas at a point before the dilution takes place. Calculate the converter efficiency using Equation 7E-7 in Section 12.7. The specification for converter efficiency in Section 13.5 must

be met. The user is cautioned that state-of-the-art NO₂ calibration gases may not be sufficiently stable and thus make it more difficult to pass the 90 percent conversion efficiency requirement. The NO₂ must be prepared according to the EPA Traceability Protocol and have an accuracy within 2.0 percent.

8.2.4.2 Alternatively, either of the procedures for determining conversion efficiency using NO in Section 16.2 may be used.

8.2.5 Initial System Bias and System Calibration Error Checks. Before sampling begins, determine whether the high-level or mid-level calibration gas best approximates the emissions and use it as the upscale gas. Introduce the upscale gas at the probe upstream of all sample conditioning components in system calibration mode. Record the time it takes for the measured concentration to increase to a value that is within 95 percent or 0.5 ppm (whichever is less restrictive) of the certified gas concentration. Continue to observe the gas concentration reading until it has reached a final, stable value. Record this value on a form similar to Table 7E-2.

(1) Next, introduce the low-level gas in system calibration mode and record the time required for the

concentration response to decrease to a value that is within 5.0 percent or 0.5 ppm (whichever is less restrictive) of the certified low-range gas concentration. If the low-level gas is a zero gas, use the procedures described above and observe the change in concentration until the response is 0.5 ppm or 5.0 percent of the upscale gas concentration (whichever is less restrictive).

(2) Continue to observe the low-level gas reading until it has reached a final, stable value and record the result on a form similar to Table 7E-2. Operate the measurement system at the normal sampling rate during all system bias checks. Make only the adjustments necessary to achieve proper calibration gas flow rates at the analyzer.

(3) From these data, calculate the measurement system response time (see Section 8.2.6) and then calculate the initial system bias using Equation 7E-2 in Section 12.3. For dilution systems, calculate the system calibration error in lieu of system bias using equation 7E-3 in Section 12.4. See Section 13.2 for acceptable performance criteria for system bias and system calibration error. If the initial system bias (or system calibration error) specification is not met, take corrective action. Then, you must repeat the applicable calibration error test from

Section 8.2.3 and the initial system bias (or 2-point system calibration error) check until acceptable results are achieved, after which you may begin sampling. (**Note:** For dilution-type systems, data from the 3-point system calibration error test described in Section 8.2.3 may be used to meet the initial 2-point system calibration error test requirement of this section, if the calibration gases were injected as described in this section, and if response time data were recorded).

8.2.6 Measurement System Response Time. As described in section 8.2.5, you must determine the measurement system response time during the initial system bias (or 2-point system calibration error) check. Observe the times required to achieve 95 percent of a stable response for both the low-level and upscale gases. The longer interval is the response time.

8.2.7 Interference Check. Conduct an interference response test of the gas analyzer prior to its initial use in the field. If you have multiple analyzers of the same make and model, you need only perform this alternative interference check on one analyzer. You may also meet the interference check requirement if the instrument manufacturer performs this or similar check on the same

make and model of analyzer that you use and provides you with documented results.

(1) You may introduce the appropriate interference test gases (that are potentially encountered during a test, see examples in Table 7E-3) into the analyzer (or measurement system for dilution-type systems) separately or as mixtures. This test must be performed both with and without NO_x (NO and NO₂) (the applicable pollutant gas). For analyzers measuring NO_x greater than 20 ppm, use a calibration gas with an NO_x concentration of 80 to 100 ppm and set this concentration equal to the calibration span. For analyzers measuring less than 20 ppm NO_x, select an NO concentration for the calibration span that reflects the emission levels at the sources to be tested, and perform the interference check at that level. Measure the total interference response of the analyzer to these gases in ppmv. Record the responses and determine the interference using Table 7E-4. The specification in Section 13.4 must be met.

(2) A copy of this data, including the date completed and signed certification, must be available for inspection at the test site and included with each test report. This interference test is valid for the life of the instrument

unless major analytical components (e.g., the detector) are replaced. If major components are replaced, the interference gas check must be repeated before returning the analyzer to service. The tester must ensure that any specific technology, equipment, or procedures that are intended to remove interference effects are operating properly during testing.

8.3 Dilution-Type Systems—Special Considerations.

When a dilution-type measurement system is used, there are three important considerations that must be taken into account to ensure the quality of the emissions data. First, the critical orifice size and dilution ratio must be selected properly so that the sample dew point will be below the sample line and analyzer temperatures. Second, a high-quality, accurate probe controller must be used to maintain the dilution ratio during the test. The probe controller should be capable of monitoring the dilution air pressure, eductor vacuum, and sample flow rates. Third, differences between the molecular weight of calibration gas mixtures and the stack gas molecular weight must be addressed because these can affect the dilution ratio and introduce measurement bias.

8.4 Sample Collection. (1) Position the probe at the first sampling point. Purge the system for at least two times the response time before recording any data. Then, traverse all required sampling points and sample at each point for an equal length of time, maintaining the appropriate sample flow rate or dilution ratio (as applicable). You must record at least one valid data point per minute during the test run. The minimum time you must sample at each point is two times the system response time. Usually the test is designed for sampling longer than this to better characterize the source's temporal variation.

(2) After recording data for the appropriate period of time at the first traverse point, you may move to the next point and continue recording, omitting the requirement to wait for two times the system response time before recording data at the subsequent traverse points. For example, if you use a sampling system with a two-minute system response time, initially purge the system for at least four minutes, then record a minimum of four one-minute averages at each sample point. However, if you remove the probe from the stack, you must recondition the sampling system for at least two times the system response time prior to your next recording. If the average of any

run exceeds the calibration span value, the run is invalidated.

(3) You may satisfy the multipoint traverse requirement by sampling sequentially using a single-hole probe or a multi-hole probe designed to sample at the prescribed points with a flow within 10 percent of mean flow rate. Notwithstanding, for applications under part 75 of this chapter, the use of multi-hole probes is subject to the approval of the Administrator.

8.5 Post-Run System Bias Check and Drift Assessment.

How do I confirm that each sample I collect is valid?

After each run, repeat the system bias check or 2-point system calibration error check (for dilution systems) to validate the run. Do not make adjustments to the measurement system (other than to maintain the target sampling rate or dilution ratio) between the end of the run and the completion of the post-run system bias or system calibration error check. Note that for all post-run system bias or 2-point system calibration error checks, you may inject the low-level gas first and the upscale gas last, or vice-versa.

(1) If you do not pass the post-run system bias (or system calibration error) check, then the run is invalid.

You must diagnose and fix the problem and pass another initial 3-point calibration error test (see Section 8.2.3) and another system bias (or 2-point system calibration error) check (see Section 8.2.5) before repeating the run. In these additional bias and calibration error tests, the gases may be injected in any order. Record the system bias (or system calibration error) check results on a form similar to Table 7E-2.

(2) After each run, calculate the low-level and upscale drift, using Equation 7E-4 in Section 12.5 . If the post-run low- and upscale bias (or 2-point system calibration error) checks are passed, but the low- or upscale drift exceeds the specification in Section 13.3, the run data are valid, but a 3-point calibration error test and a system bias (or 2-point system calibration error) check must be performed and passed before any more test runs are done.

(3) For dilution systems, data from a 3-point system calibration error test may be used to meet the pre-run 2-point system calibration error requirement for the first run in a test sequence. Also, the post-run bias (or 2-point calibration error) check data may be used as the pre-

run data for the next run in the test sequence at the discretion of the tester.

8.6 Alternative Interference and System Bias Checks (Dynamic Spike Procedure). **If I want to use the dynamic spike procedure to validate my data, what procedure should I follow?** Except for applications under part 75 of this chapter, you may use the dynamic spiking procedure and requirements provided in Section 16.1 during each test as an alternative to the interference check and the pre- and post-run system bias checks. The calibration error test is still required under this option. Use of the dynamic spiking procedure for Part 75 applications is subject to the approval of the Administrator.

8.7 Moisture correction. You must determine the moisture content of the flue gas and correct the measured gas concentrations to a dry basis using Method 4 or other appropriate methods, subject to the approval of the Administrator, when the moisture basis (wet or dry) of the measurements made with this method is different from the moisture basis of either: (1) the applicable emissions limit; or (2) the CEMS being evaluated for relative accuracy. Moisture correction is also required if the applicable limit is in lb/mmBtu and the moisture basis of

the Method 7E NO_x analyzer is different from the moisture basis of the Method 3A diluent gas (CO₂ or O₂) analyzer.

9.0 Quality Control

What quality control measures must I take?

The following table is a summary of the mandatory, suggested, and alternative quality assurance and quality control measures and the associated frequency and acceptance criteria. All of the QC data, along with the sample run data, must be documented and included in the test report.

Summary Table of QA/QC

Stat us	Process or Element	QA/QC Specification	Acceptance Criteria	Checking Frequency
S	Identify Data User		Regulatory Agency or other primary end user of data	Before designing test
S	Analyzer Design	Analyzer resolution or sensitivity	< 2.0 % of full-scale range	Manufacturer design
M		Interference gas check	Sum of responses \leq 2.5 % of calibration span Alternatively, sum of responses: \leq 0.5 ppmv for calibration spans of 5 to 10 ppmv \leq 0.2 ppmv for calibration spans < 5 ppmv See Table 7E-3	
M	Calibrati on Gases	Traceability protocol (G1, G2)	Valid certificate required Uncertainty \leq 2.0 % of tag value	
M		High-level gas	Equal to the calibration span	Each test
M		Mid-level gas	40 to 60% of calibration span	Each test
M		Low-level gas	< 20% of calibration span	Each test

S	Data Recorder Design	Data resolution	≤ 0.5% of full-scale range	Manufacturer design
S	Sample Extraction	Probe material	SS or quartz if stack > 500° F	Each test
M	Sample Extraction	Probe, filter and sample line temperature	For dry-basis analyzers, keep sample above the dew point by heating, prior to sample conditioning For wet-basis analyzers, keep sample above dew point at all times, by heating or dilution.	Each run
S	Sample Extraction	Calibration valve material	SS	Each test
S	Sample Extraction	Sample pump material	Inert to sample constituents	Each test
S	Sample Extraction	Manifolding material	Inert to sample constituents	Each test
S	Moisture Removal	Equipment efficiency	< 5% target compound removal	Verified through system bias check
S	Particulate Removal	Filter inertness	Pass system bias check	Each bias check

M	Analyzer & Calibration Gas Performance	Analyzer calibration error (or 3-point system calibration error for dilution systems)	Within ± 2.0 percent of the calibration span of the analyzer for the low-, mid-, and high-level calibration gases Alternative specification: 0.5 ppmv absolute difference	Before initial run and after a failed system bias test or drift test
M	System Performance	System bias (or pre- and post-run 2-point system calibration error for dilution Systems)	Within ± 5.0 % of the analyzer calibration span for low-scale and upscale calibration gases Alternative specification: 0.5 ppmv absolute difference	Before and after each run
M	System Performance	System response time	Determines minimum sampling time per point	During initial sampling system bias test
M	System Performance	Drift	.3.0 % of calibration span for low-level and mid- or high-level gases Alternative specification: 0.5 ppmv absolute difference	After each test run
M	System Performance	NO ₂ -NO conversion efficiency	$\geq 90\%$ of certified test gas concentration	Before each test

M	System Performance	Purge time	≥ 2 times system response time	Before starting the first run and when probe is removed from and re-inserted into the stack
M	System Performance	Minimum sample time at each point	Two times the system response time	Each sample point
M	System Performance	Stable sample flow rate (surrogate for maintaining system response time)	Within 10% of flow rate established during system response time check	Each run
M	Sample Point Selection	Stratification test	All points within: $\pm 5\%$ of mean for 1-point sampling $\pm 10\%$ of mean for 3-point Alternatively, all points within: ± 0.5 ppm of mean for 1-point sampling ± 1.0 ppm of mean for 3-point sampling	Prior to first run

A	Multiple sample points simultaneously	No. of openings in probe	Multi-hole probe with verifiable constant flow through all holes within 10% of mean flow rate (requires Administrative approval for Part 75)	Each run
M	Data Recording	Frequency	1 minute average	During run
S	Data Parameters	Sample concentration range	All 1-minute averages within calibration span	Each run
M	Data Parameters	Average concentration for the run	Run average \leq calibration span	Each run

S = Suggested

M = Mandatory

A = Alternative

10.0 Calibration and Standardization

What measurement system calibrations are required?

(1) The initial 3-point calibration error test as described in Section 8.2.3 and the system bias (or system calibration error) checks described in Section 8.2.5 are required and must meet the specifications in Section 13 before you start the test. Make all necessary adjustments to calibrate the gas analyzer and data recorder. Then, after the test commences, the system bias or system calibration error checks described in Section 8.5 are required before and after each run. Your analyzer must be calibrated for all species of NO_x that it detects. If your analyzer measures NO and NO₂ separately, then you must use both NO and NO₂ calibration gases.

(2) You must include a copy of the manufacturer's certification of the calibration gases used in the testing as part of the test report. This certification must include the 13 documentation requirements in the EPA Traceability Protocol For Assay and Certification of Gaseous Calibration Standards, September 1997, as amended August 25, 1999. When Method 205 is used to produce diluted calibration gases, you must document that the specifications for the gas dilution system are met for the test. You must also include the date of the most recent dilution system calibration against flow standards and the name

of the person or manufacturer who carried out the calibration in the test report.

11.0 Analytical Procedures

Because sample collection and analysis are performed together (see Section 8), additional discussion of the analytical procedure is not necessary.

12.0 Calculations and Data Analysis

You must follow the procedures for calculations and data analysis listed in this section.

12.1 Nomenclature. The terms used in the equations are defined as follows:

ACE = Analyzer calibration error, percent of calibration span.

B_{WS} = Moisture content of sample gas as measured by Method 4 or other approved method, percent/100.

C_{AVG} = Average unadjusted gas concentration indicated by data recorder for the test run, ppmv.

C_D = Pollutant concentration adjusted to dry conditions, ppmv.

C_{Dir} = Measured concentration of a calibration gas (low, mid, or high) when introduced in direct calibration mode, ppmv.

- C_{Gas} = Average effluent gas concentration adjusted for bias, ppmv.
- C_M = Average of initial and final system calibration bias (or 2-point system calibration error) check responses for the upscale calibration gas, ppmv.
- C_{MA} = Actual concentration of the upscale calibration gas, ppmv.
- C_0 = Average of the initial and final system calibration bias (or 2-point system calibration error) check responses from the low-level (or zero) calibration gas, ppmv.
- C_S = Measured concentration of a calibration gas (low, mid, or high) when introduced in system calibration mode, ppmv.
- C_{SS} = Concentration of NO_x measured in the spiked sample, ppmv.
- C_{Spike} = Concentration of NO_x in the undiluted spike gas, ppmv.
- C_{Calc} = Calculated concentration of NO_x in the spike gas diluted in the sample, ppmv.
- C_V = Manufacturer certified concentration of a calibration gas (low, mid, or high), ppmv.

- C_w = Pollutant concentration measured under moist sample conditions, wet basis, ppmv.
- CS = Calibration span, ppmv.
- D = Drift assessment, percent of calibration span.
- Eff_{NO_2} = NO_2 to NO converter efficiency, percent.
- NO_{Final} = The average NO concentration observed with the analyzer in the NO mode during the converter efficiency test in Section 16.2.2, ppmv.
- NO_{XCorr} = The NO_x concentration corrected for the converter efficiency, ppmv.
- NO_{XFinal} = The final NO_x concentration observed during the converter efficiency test in Section 16.2.2, ppmv.
- NO_{XPeak} = The highest NO_x concentration observed during the converter efficiency test in Section 16.2.2, ppmv.
- Q_{Spike} = Flow rate of spike gas introduced in system calibration mode, L/min.
- Q_{Total} = Total sample flow rate during the spike test, L/min.
- R = Spike recovery, percent.
- SB = System bias, percent of calibration span.
- SB_i = Pre-run system bias, percent of calibration

span.

SB_f = Post-run system bias, percent of calibration span.

SCE = System calibration error, percent of calibration span.

SCE_i = Pre-run system calibration error, percent of calibration span.

SCE_{final} = Post-run system calibration error, percent of calibration span.

12.2 Analyzer Calibration Error. For non-dilution systems, use Equation 7E-1 to calculate the analyzer calibration error for the low-, mid-, and high-level calibration gases.

$$ACE = \frac{C_{Dir} - C_v}{CS} \times 100 \quad \text{Eq. 7E-1}$$

12.3 System Bias. For non-dilution systems, use Equation 7E-2 to calculate the system bias separately for the low-level and upscale calibration gases.

$$SB = \frac{C_s - C_{Dir}}{CS} \times 100 \quad \text{Eq. 7E-2}$$

12.4 System Calibration Error. Use Equation 7E-3 to calculate the system calibration error for dilution systems. Equation 7E-3 applies to both the initial 3-point system calibration error test and the subsequent 2-point between run tests.

$$SCE = \frac{C_s - C_v}{CS} \times 100 \quad \text{Eq. 7E-3}$$

12.5 Drift Assessment. Use Equation 7E-4 to separately calculate the low-level and upscale drift over each test run. For dilution systems, replace "SB_{final}" and "SB_i" with "SCE_{final}" and "SCE_i", respectively, to calculate and evaluate drift.

$$D = |SB_{final} - SB_i| \quad \text{Eq. 7E-4}$$

12.6 Effluent Gas Concentration. For each test run, calculate C_{avg}, the arithmetic average of all valid NO_x concentration values (e.g., 1-minute averages). Then adjust the value of C_{avg} for bias, using Equation 7E-5.

$$C_{Gas} = (C_{Avg} - C_o) \frac{C_{MA}}{C_M - C_o} \quad \text{Eq. 7E-5}$$

12.7 NO₂ - NO Conversion Efficiency. If the NO_x converter efficiency test described in Section 8.2.4.1 is performed, calculate the efficiency using Equation 7E-7.

$$Eff_{NO_2} = \frac{C_{Dir}}{C_v} \times 100 \quad \text{Eq. 7E-7}$$

12.8 NO₂ - NO Conversion Efficiency Correction. If desired, calculate the total NO_x concentration with a correction for converter efficiency using Equations 7E-8.

$$NO_{XCorr} = NO + \frac{NO_x - NO}{Eff_{NO_2}} \times 100 \quad \text{Eq. 7E-8}$$

12.9 Alternative NO₂ Converter Efficiency. If the alternative procedure of Section 16.2.2 is used, calculate the converter efficiency using Equation 7E-9.

$$Eff_{NO_2} = \frac{(NO_{XFinal} - NO_{Final})}{(NO_{XPeak} - NO_{XFinal})} \times 100 \quad \text{Eq. 7E-9}$$

12.10 Moisture Correction. Use Equation 7E-10 if your measurements need to be corrected to a dry basis.

$$C_D = \frac{C_W}{1 - B_{WS}} \quad \text{Eq. 7E-10}$$

12.11 Calculated Spike Gas Concentration and Spike Recovery for the Example Alternative Dynamic Spiking Procedure in Section 16.1.3. Use Equation 7E-11 to determine the calculated spike gas concentration. Use Equation 7E-12 to calculate the spike recovery.

$$C_{Calc} = \frac{(C_{Spike})(Q_{Spike})}{Q_{Total}} \quad \text{Eq. 7E-11}$$

$$R = \frac{C_{SS} - C_{Avg}}{C_{Calc}} \times 100 \quad \text{Eq. 7E-12}$$

13.0 Method Performance

13.1 Calibration Error. This specification is applicable to both the analyzer calibration error and the 3-point system calibration error tests described in Section 8.2.3. At each calibration gas level (low, mid, and high) the calibration error must either be within ± 2.0 percent of the calibration span.

Alternatively, the results are acceptable if $|C_{dir} - C_v|$ or $|C_s - C_v|$ (as applicable) is ≤ 0.5 ppmv.

13.2 System Bias. This specification is applicable to both the system bias and 2-point system calibration error tests described in Section 8.2.5 and 8.5. The pre- and post-run system bias (or system calibration error) must be within ± 5.0 percent of the calibration span for the low-level and upscale calibration gases. Alternatively, the results are acceptable if $|C_s - C_{dir}|$ is ≤ 0.5 ppmv or if $|C_s - C_v|$ is ≤ 0.5 ppmv (as applicable).

13.3 Drift. For each run, the low-level and upscale drift must be less than or equal to 3.0 percent of the calibration span. The drift is also acceptable if the pre- and post-run bias (or the pre- and post-run system calibration error) responses do not differ by more than 0.5 ppmv at each gas concentration (i.e. $|C_{s \text{ post-run}} - C_{s \text{ pre-run}}| \leq 0.5$ ppmv).

13.4 Interference Check. The total interference response (i.e., the sum of the interference responses of all tested gaseous components) must not be greater than 2.50 percent of the calibration span for the analyzer tested. In summing the interferences, use the larger of the absolute values obtained for the interferent tested with and without the pollutant present. The results are also acceptable if the sum of the

responses does not exceed 0.5 ppmv for a calibration span of 5 to 10 ppmv, or 0.2 ppmv for a calibration span < 5 ppmv.

13.5 NO₂ to NO Conversion Efficiency Test (as applicable). The NO₂ to NO conversion efficiency, calculated according to Equation 7E-7 or Equation 7E-9, must be greater than or equal to 90 percent.

13.6 Alternative Dynamic Spike Procedure. Recoveries of both pre-test spikes and post-test spikes must be within 100 ± 10 percent. If the absolute difference between the calculated spike value and measured spike value is equal to or less than 0.20 ppmv, then the requirements of the ADSC are met.

14.0 Pollution Prevention [Reserved]

15.0 Waste Management [Reserved]

16.0 Alternative Procedures

16.1 Dynamic Spike Procedure. Except for applications under part 75 of this chapter, you may use a dynamic spiking procedure to validate your test data for a specific test matrix in place of the interference check and pre- and post-run system bias checks. For part 75 applications, use of this procedure is subject to the approval of the Administrator. Best results are obtained for this procedure when source emissions are steady and not varying. Fluctuating emissions may render this alternative

procedure difficult to pass. To use this alternative, you must meet the following requirements.

16.1.1 Procedure Documentation. You must detail the procedure you followed in the test report, including how the spike was measured, added, verified during the run, and calculated after the test.

16.1.2 Spiking Procedure Requirements. The spikes must be prepared from EPA Traceability Protocol gases. Your procedure must be designed to spike field samples at two target levels both before and after the test. Your target spike levels should bracket the average sample NO_x concentrations. The higher target concentration must be less than the calibration span. You must collect at least 5 data points for each target concentration. The spiking procedure must be performed before the first run and repeated after the last run of the test program.

16.1.3 Example Spiking Procedure. Determine the NO concentration needed to generate concentrations that are 50 and 150 percent of the anticipated NO_x concentration in the stack at the total sampling flow rate while keeping the spike flow rate at or below 10 percent of this total. Use a mass flow meter (accurate within 2.0 percent) to generate these NO spike gas concentrations at a constant flow rate. Use Equation 7E-11 in

Section 12.11 to determine the calculated spike concentration in the collected sample.

(1) Prepare the measurement system and conduct the analyzer calibration error test as described in Sections 8.2.2 and 8.2.3. Following the sampling procedures in Section 8.1, determine the stack NO_x concentration and use this concentration as the average stack concentration (C_{avg}) for the first spike level, or if desired, for both pre-test spike levels. Introduce the first level spike gas into the system in system calibration mode and begin sample collection. Wait for at least two times the system response time before measuring the spiked sample concentration. Then record at least five successive 1-minute averages of the spiked sample gas. Monitor the spike gas flow rate and maintain at the determined addition rate. Average the five 1-minute averages and determine the spike recovery using Equation 7E-12. Repeat this procedure for the other pre-test spike level. The recovery at each level must be within the limits in Section 13.6 before proceeding with the test.

(2) Conduct the number of runs required for the test. Then repeat the above procedure for the post-test spike evaluation. The last run of the test may serve as the average stack concentration for the post-test spike test calculations.

The results of the post-test spikes must meet the limits in Section 13.6.

16.2 Alternative NO₂ to NO Conversion Efficiency Procedures. You may use either of the following procedures to determine converter efficiency in place of the procedure in Section 8.2.4.1.

16.2.1 The procedure for determining conversion efficiency using NO in 40 CFR 86.123-78.

16.2.2 Tedlar Bag Procedure. Perform the analyzer calibration error test to document the calibration (both NO and NO_x modes, as applicable). Fill a Tedlar bag approximately half full with either ambient air, pure oxygen, or an oxygen standard gas with at least 19.5 percent by volume oxygen content. Fill the remainder of the bag with mid-level NO in nitrogen calibration gas. (Note that the concentration of the NO standard should be sufficiently high that the diluted concentration will be easily and accurately measured on the scale used. The size of the bag should be large enough to accommodate the procedure and time required).

(1) Immediately attach the bag to the inlet of the NO_x analyzer (or external converter if used). In the case of a dilution-system, introduce the gas at a point upstream of the dilution assembly. Measure the NO_x concentration for a period of

30 minutes. If the NO_x concentration drops more than 2 percent absolute from the peak value observed, then the NO_2 converter has failed to meet the criteria of this test. Take corrective action. The highest NO_x value observed is considered to be $\text{NO}_{x\text{Peak}}$. The final NO_x value observed is considered to be $\text{NO}_{x\text{final}}$.

(2) If the NO_x converter has met the criterion of this test, then switch the analyzer to the NO mode (note that this may not be required for analyzers with auto-switching). Document the average NO concentration for a period of 30 seconds to one minute. This average value is NO_{final} . Switch the analyzer back to the NO_x mode and document that the analyzer still meets the criteria of not dropping more than 2 percent from the peak value.

(3) In sequence, inject the zero and the upscale calibration gas that most closely matches the NO_x concentration observed during the converter efficiency test. Repeat this procedure in both the NO and NO_x modes. If the gases are not within 1 percent of scale of the actual values, reject the converter efficiency test and take corrective action. If the gases are within this criterion, use Equation 7E-9 to determine the converter efficiency. The converter efficiency must meet the specification in Section 13.5.

16.3 Manufacturer's Stability Test. A manufacturer's stability test is required for all analyzers that routinely measure emissions below 20 ppm and is optional but recommended for other analyzers. This test evaluates each analyzer model by subjecting it to the tests listed in Table 7E-5 following the procedures in 40 CFR Part 53.23, 53.55, and 53.56 to demonstrate its stability. A copy of this information in summary format must be included in each test report.

17.0 References

1. "EPA Traceability Protocol for Assay and Certification of Gaseous Calibration Standards" September 1997 as amended, EPA-600/R-97/121.

18.0 Tables, Diagrams, Flowcharts, and Validation Data

Figure 7E-1. Measurement System

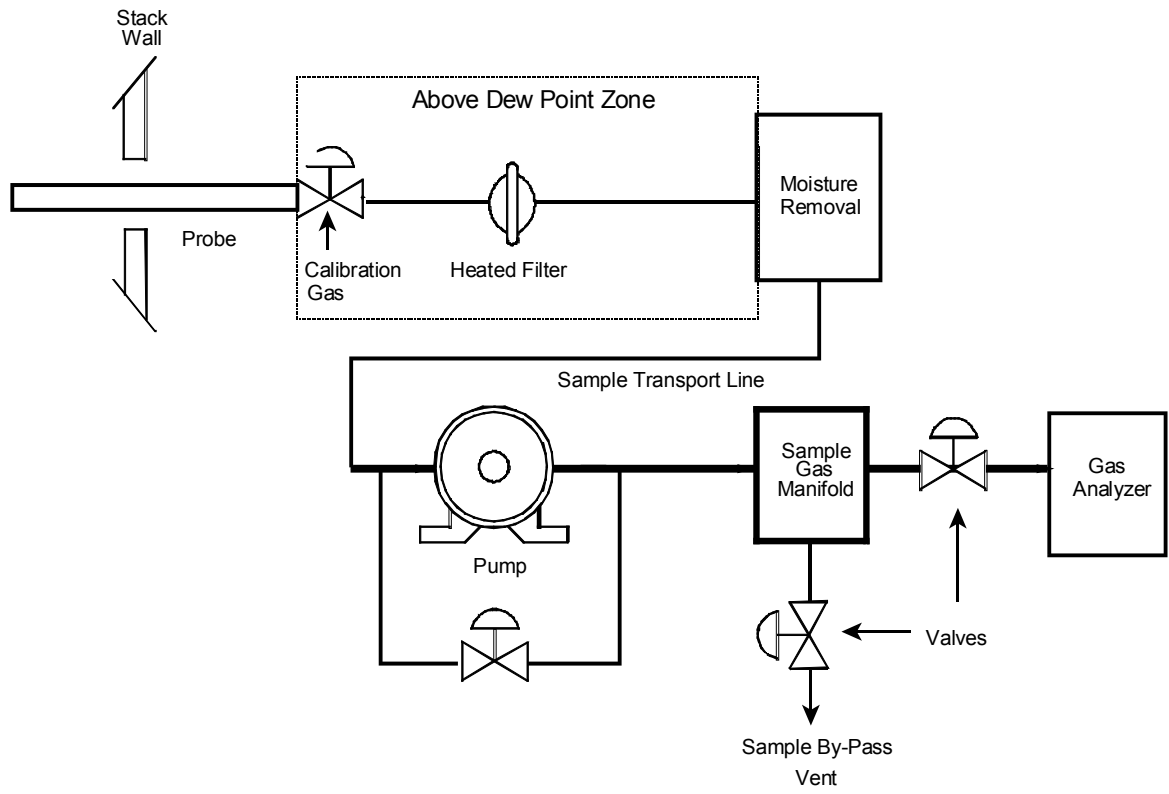

Figure 7E-2. Testing Flow Chart

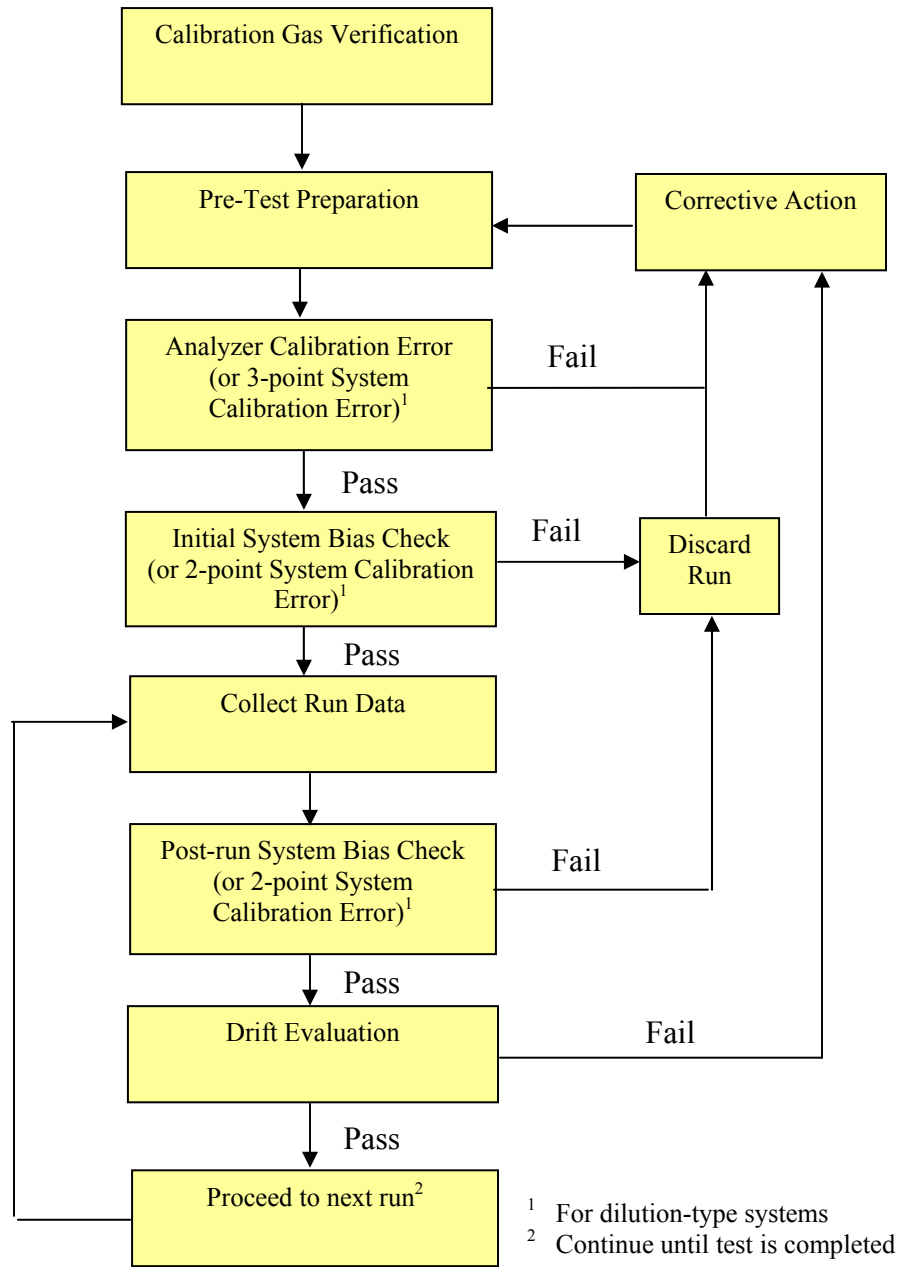

Table 7E-1 - Analyzer (or System) Calibration Error Data

Source Identification:		Analyzer ¹ or System ² calibration error data for		
Test personnel: _____		sampling		
Date: _____		runs: _____		
Time: _____		Analyzer Model		
		No. _____		
		Serial		
		No. _____		
		Calibration Span (CS):		
	Manufacturer Certified Cylinder Value (indicate units)	Analyzer calibration response (indicate units)	Absolute difference (indicate units)	Calibration Error (percent of calibration span)
	A	B	A-B	$\frac{A-B}{CS} \times 100$
Low-level (or zero) calibration gas
Mid-level calibration gas.....
High-level calibration gas.....

¹ Refers to data from the analyzer calibration error test of a non-dilution system.

² Refers to data from a 3-point system calibration error test of a dilution system.

Table 7E-2 - System Bias (or System Calibration Error) and Drift Data

Source Identification: _____ Run Number: _____
 Test personnel: _____ Calibration Span: _____
 Date: _____ Response Time: _____
 Analyzer Model No. _____ Serial No. _____

Calibration Gas Level	Initial values			Final values		
	Certified Calibration gas value (indicate units)	System Response (indicate units)	System Bias ¹ or Calibration Error ² (% of calibration span)	System response (indicate units)	System Bias ¹ or Calibration Error ² (% of calibration span)	Drift (% of calibration span)
Low-level gas
Upscale (high- or mid-) level gas

¹ Refers to the pre- and post-run system bias checks of a non-dilution system.

² Refers to the pre- and post-run system calibration error checks of a dilution system.

Table 7E-3. Interference Check Gas Concentrations

Potential Interferent	Sample Conditioning Type ²	
	Hot Wet	Dried
CO ₂	5 and 15%	5 and 15%
H ₂ O	25%	1 %
NO	15 ppmv	15 ppmv
NO ₂	15 ppmv	15 ppmv
N ₂ O	10 ppmv	10 ppmv
CO	50 ppmv	50 ppmv
NH ₃	10 ppmv	10 ppmv
CH ₄	50 ppmv	50 ppmv
SO ₂	20 ppmv	20 ppmv
H ₂	50 ppmv	50 ppmv
HCl	10 ppmv	10 ppmv

- 1) Any of the above specific gases can be eliminated or tested at a lower level if the manufacturer has provided reliable means for limiting or scrubbing that gas to a specified level.
- 2) For dilution extractive systems, use the Hot Wet concentrations divided by the minimum targeted dilution ratio to be used during the test.

Table 7E-4 - Interference Response

Date of Test: _____
 Analyzer Type: _____
 Model No.: _____
 Serial No: _____
 Calibration Span: _____

Test Gas Type	Concentration (ppm)	Analyzer Response
Sum of Responses		
% of Calibration Span		

Table 7E-5. Manufacturer Stability Test*Each Model Must Be Tested Quarterly or Once Per 50 Production Units*

TEST DESCRIPTION	Acceptance Criteria (Note 1)
Thermal Stability	Temperature range when drift does not exceed 3.0% of analyzer range over a 12-hour run when measured with NO _x present @ . 80% of calibration span.
Fault Conditions	Identify conditions which, when they occur, result in performance which is not in compliance with the Manufacturer's Stability Test criteria. These are to be indicated visually or electrically to alert the operator of the problem.
Insensitivity to Supply Voltage Variations	±10.0% (or manufacturers alternative) variation from nominal voltage must produce a drift of ≤ 2.0% of calibration span for either zero or concentration ≥ 80% NO _x present
Analyzer Calibration Error	For a low-, medium-, and high- calibration gas, the difference between the manufacturer certified value and the analyzer response in direct calibration mode, no more than 2.0% of calibration span

Note 1: If the instrument is to be used as a Low Range analyzer, all tests must be performed at a calibration span of 20 ppm or less.

* * * * *

**METHOD 10 - DETERMINATION OF CARBON MONOXIDE EMISSIONS FROM
STATIONARY SOURCES
(INSTRUMENTAL ANALYZER PROCEDURE)**

1.0 Scope and Application

What is Method 10?

Method 10 is a procedure for measuring carbon monoxide (CO) in stationary source emissions using a continuous instrumental analyzer. Quality assurance and quality control requirements are included to assure that you, the tester, collect data of known quality. You must document your adherence to these specific requirements for equipment, supplies, sample collection and analysis, calculations, and data analysis. This method does not completely describe all equipment, supplies, and sampling and analytical procedures you will need but refers to other methods for some of the details. Therefore, to obtain reliable results, you should also have a thorough knowledge of these additional test methods which are found in appendix A to this part:

(a) Method 1—Sample and Velocity Traverses for Stationary Sources.

(b) Method 4—Determination of Moisture Content in Stack Gases.

(c) Method 7E—Determination of Nitrogen Oxides Emissions from Stationary Sources (Instrumental Analyzer Procedure).

1.1 Analytes. **What does this method determine?** This method measures the concentration of carbon monoxide.

Analyte	CAS No.	Sensitivity
CO	630-08-0	Typically <2% of Calibration Span

1.2 Applicability. **When is this method required?**

The use of Method 10 may be required by specific New Source Performance Standards, State Implementation Plans, and permits where CO concentrations in stationary source emissions must be measured, either to determine compliance with an applicable emission standard or to conduct performance testing of a continuous emission monitoring system (CEMS). Other regulations may also require the use of Method 10.

1.3 Data Quality Objectives. Refer to Section 1.3 of Method 7E.

2.0 Summary of Method

In this method, you continuously or intermittently sample the effluent gas and convey the sample to an analyzer that measures the concentration of CO. You must meet the performance requirements of this method to validate your data.

3.0 Definitions

Refer to Section 3.0 of Method 7E for the applicable definitions.

4.0 Interferences

Substances having a strong absorption of infrared energy may interfere to some extent in some analyzers. Instrumental correction may be used to compensate for the interference. You may also use silica gel and ascarite traps to eliminate the interferences. If this option is used, correct the measured gas volume for the carbon dioxide (CO₂) removed in the trap.

5.0 Safety

Refer to Section 5.0 of Method 7E.

6.0 Equipment and Supplies

What do I need for the measurement system?

6.1 Continuous Sampling. Figure 7E-1 of Method 7E is a schematic diagram of an acceptable measurement system.

The components are the same as those in Sections 6.1 and 6.2 of Method 7E, except that the CO analyzer described in Section 6.2 of this method must be used instead of the analyzer described in Section 6.2 of Method 7E. You must follow the noted specifications in Section 6.1 of Method 7E except that the requirements to use stainless steel, Teflon, or non-reactive glass filters do not apply. Also, a heated sample line is not required to transport dry gases or for systems that measure the CO concentration on a dry basis.

6.2 Integrated Sampling.

6.2.1 Air-Cooled Condenser or Equivalent. To remove any excess moisture.

6.2.2 Valve. Needle valve, or equivalent, to adjust flow rate.

6.2.3 Pump. Leak-free diaphragm type, or equivalent, to transport gas.

6.2.4 Rate Meter. Rotameter, or equivalent, to measure a flow range from 0 to 1.0 liter per minute (0.035 cfm).

6.2.5 Flexible Bag. Tedlar, or equivalent, with a capacity of 60 to 90 liters (2 to 3 ft³). Leak-test the bag in the laboratory before using by evacuating with a pump

followed by a dry gas meter. When the evacuation is complete, there should be no flow through the meter.

6.3 What analyzer must I use? You must use an instrument that continuously measures CO in the gas stream and meets the specifications in Section 13.0. The dual-range analyzer provisions in Section 6.2.8.1 of Method 7E apply.

7.0 Reagents and Standards

7.1 Calibration Gas. What calibration gases do I need? Refer to Section 7.1 of Method 7E for the calibration gas requirements.

7.2 Interference Check. What additional reagents do I need for the interference check? Use the appropriate test gases listed in Table 7E-3 of Method 7E (i.e., potential interferences, as identified by the instrument manufacturer) to conduct the interference check.

8.0 Sample Collection, Preservation, Storage, and Transport

Emission Test Procedure

8.1 Sampling Site and Sampling Points. You must follow Section 8.1 of Method 7E.

8.2 Initial Measurement System Performance Tests. You must follow the procedures in Section 8.2 of Method 7E.

If a dilution-type measurement system is used, the special considerations in Section 8.3 of Method 7E also apply.

8.3 Interference Check. You must follow the procedures of Section 8.2.7 of Method 7E.

8.4 Sample Collection.

8.4.1 Continuous Sampling. You must follow the procedures of Section 8.4 of Method 7E.

8.4.2 Integrated Sampling. Evacuate the flexible bag. Set up the equipment as shown in Figure 10-1 with the bag disconnected. Place the probe in the stack and purge the sampling line. Connect the bag, making sure that all connections are leak-free. Sample at a rate proportional to the stack velocity. If needed, the CO₂ content of the gas may be determined by using the Method 3 integrated sample procedures, or by weighing an ascarite CO₂ removal tube used and computing CO₂ concentration from the gas volume sampled and the weight gain of the tube.

Data may be recorded on a form similar to Table 10-1.

8.5 Post-Run System Bias Check, Drift Assessment, and Alternative Dynamic Spike Procedure. You must follow the procedures in Sections 8.5 and 8.6 of Method 7E.

9.0 Quality Control

Follow the quality control procedures in Section 9.0 of Method 7E.

10.0 Calibration and Standardization

Follow the procedures for calibration and standardization in Section 10.0 of Method 7E.

11.0 Analytical Procedures

Because sample collection and analysis are performed together (see Section 8), additional discussion of the analytical procedure is not necessary.

12.0 Calculations and Data Analysis

You must follow the procedures for calculations and data analysis in Section 12.0 of Method 7E, as applicable, substituting CO for NO_x as applicable.

12.1 Concentration Correction for CO₂ Removal.

Correct the CO concentration for CO₂ removal (if applicable) using Eq. 10-1.

$$C_{Avg} = C_{COstack} (1 - F_{CO2})$$

Where:

C_{Avg} = Average gas concentration for the test run,
ppm.

$C_{CO\ stack}$ = Average unadjusted stack gas CO concentration
indicated by the data recorder for the test
run, ppmv.

F_{CO_2} = Volume fraction of CO_2 in the sample, i.e., percent CO_2 from Orsat analysis divided by 100.

13.0 Method Performance

The specifications for analyzer calibration error, system bias, drift, interference check, and alternative dynamic spike procedure are the same as in Section 13.0 of Method 7E.

14.0 Pollution Prevention [Reserved]

15.0 Waste Management [Reserved]

16.0 Alternative Procedures

The dynamic spike procedure and the manufacturer stability test are the same as in Sections 16.1 and 16.3 of Method 7E

17.0 References

1. "EPA Traceability Protocol for Assay and Certification of Gaseous Calibration Standards" September 1997 as amended, EPA-600/R-97/121

18.0 Tables, Diagrams, Flowcharts, and Validation Data

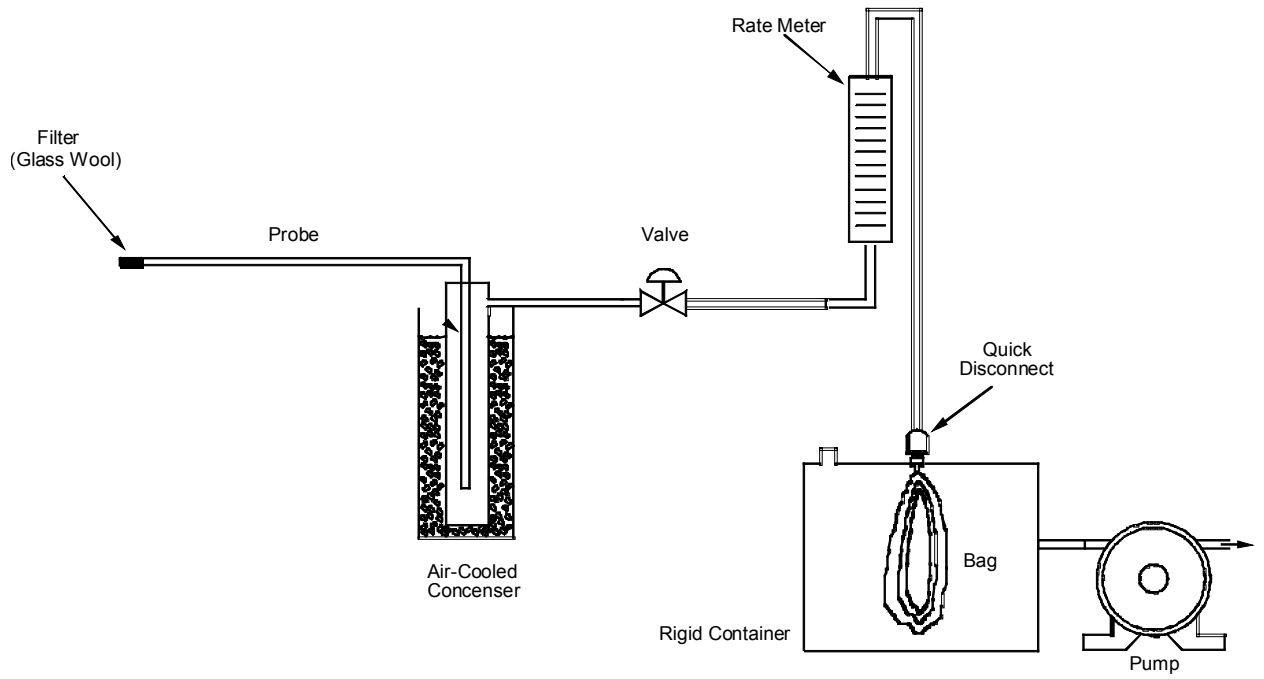
Figure 10-1. Integrated Gas Sampling Train.

* * * * *

4. Appendix A-7 is amended by revising Method 20 to read as follows:

Appendix A-7 to Part 60 - Test Methods 19 through 25E

* * * * *

METHOD 20 - DETERMINATION OF NITROGEN OXIDES, SULFUR DIOXIDE, AND DILUENT EMISSIONS FROM STATIONARY GAS TURBINES

1.0 Scope and Application

What is Method 20?

Method 20 contains the details you must follow when using an instrumental analyzer to determine concentrations of nitrogen oxides, oxygen, carbon dioxide, and sulfur dioxide in the emissions from stationary gas turbines. This method follows the specific instructions for equipment and performance requirements, supplies, sample collection and analysis, calculations, and data analysis in the methods listed in Section 2.0.

1.1 Analytes. **What does this method determine?**

Analyte	CAS No.	Sensitivity
Nitrogen oxides (NO _x) as nitrogen dioxide Nitric oxide (NO) Nitrogen dioxide (NO ₂)	10102-43-9 10102-44-0	Typically <2% of Calibration Span
Diluent oxygen (O ₂) or carbon dioxide (CO ₂)		Typically <2% of Calibration Span
Sulfur dioxide (SO ₂)	7446-09-5	Typically <2% of Calibration Span

1.2 Applicability. **When is this method required?**

The use of Method 20 may be required by specific New Source Performance Standards, Clean Air Marketing rules, and State Implementation Plans and permits where measuring SO₂, NO_x, CO₂, and/or O₂ concentrations in stationary gas turbines emissions are required. Other regulations may also require its use.

1.3 Data Quality Objectives. **How good must my collected data be?** Refer to Section 1.3 of Method 7E.

2.0 Summary of Method

In this method, NO_x, O₂ (or CO₂), and SO₂ are measured using the following methods found in appendix A to this part:

(a) Method 1—Sample and Velocity Traverses for Stationary Sources.

(b) Method 3A—Determination of Oxygen and Carbon Dioxide Emissions From Stationary Sources (Instrumental Analyzer Procedure).

(c) Method 6C—Determination of Sulfur Dioxide Emissions From Stationary Sources (Instrumental Analyzer Procedure).

(d) Method 7E—Determination of Nitrogen Oxides Emissions From Stationary Sources (Instrumental Analyzer Procedure).

(e) Method 19—Determination of Sulfur Dioxide Removal Efficiency and Particulate Matter, Sulfur Dioxide, and Nitrogen Oxide Emission Rates.

3.0 Definitions

Refer to Section 3.0 of Method 7E for the applicable definitions.

4.0 Interferences

Refer to Section 4.0 of Methods 3A, 6C, and 7E as applicable.

5.0 Safety

Refer to Section 5.0 of Method 7E.

6.0 Equipment and Supplies

The measurement system design is shown in Figure 7E-1 of Method 7E. Refer to the appropriate methods listed in Section 2.0 for equipment and supplies.

7.0 Reagents and Standards

Refer to the appropriate methods listed in Section 2.0 for reagents and standards.

8.0 Sample Collection, Preservation, Storage, and Transport

8.1 Sampling Site and Sampling Points. Follow the procedures of Section 8.1 of Method 7E. For the stratification test in Section 8.1.2, determine the diluent-corrected pollutant concentration at each traverse point.

8.2 Initial Measurement System Performance Tests. You must refer to the appropriate methods listed in Section 2.0 for the measurement system performance tests as applicable.

8.3 Interference Check. You must follow the procedures in Section 8.3 of Method 3A or 6C, or Section 8.2.7 of Method 7E (as appropriate).

8.4 Sample Collection. You must follow the procedures of Section 8.4 of the appropriate methods listed in Section 2.0.

8.5 Post-Run System Bias Check, Drift Assessment, and Alternative Dynamic Spike Procedure. You must follow the procedures of Sections 8.5 and 8.6 of the appropriate methods listed in Section 2.0.

9.0 *Quality Control*

Follow quality control procedures in Section 9.0 of Method 7E.

10.0 *Calibration and Standardization*

Follow the procedures for calibration and standardization in Section 10.0 of Method 7E.

11.0 *Analytical Procedures*

Because sample collection and analysis are performed together (see Section 8), additional discussion of the analytical procedure is not necessary.

12.0 *Calculations and Data Analysis*

You must follow the procedures for calculations and data analysis in Section 12.0 of the appropriate method

listed in Section 2.0. Follow the procedures in Section 12.0 of Method 19 for calculating fuel-specific F factors, diluent-corrected pollutant concentrations, and emission rates.

13.0 Method Performance

The specifications for the applicable performance checks are the same as in Section 13.0 of Method 7E.

14.0 Pollution Prevention [Reserved]

15.0 Waste Management [Reserved]

16.0 Alternative Procedures

Refer to Section 16.0 of the appropriate method listed in Section 2.0 for alternative procedures.

17.0 References

Refer to Section 17.0 of the appropriate method listed in Section 2.0 for references.

18.0 Tables, Diagrams, Flowcharts, and Validation Data

Refer to Section 18.0 of the appropriate method listed in Section 2.0 for tables, diagrams, flowcharts, and validation data.

* * * * *